

Stereo Digital Audio Amplifier with Headphone Driver

Features

- 16/18/20/24-bit input with I²S data format
- PSNR & DR (A-weighting)
Loudspeaker: 98dB (PSNR), 106dB (DR)
Headphone: 87dB (PSNR), 96dB (DR)
- Multiple sampling frequencies (Fs)
8KHz, 12KHz, 16KHz, 22.05KHz, 24KHz
32KHz, 44.1KHz, 48KHz,
64KHz, 88.2KHz and 96KHz
- System clock = 256Fs
- 8Fs switching for loudspeakers and headphones
- Single or dual supply
Single supply: 3.0~3.3V for the whole chip
Dual supply: 3.0~5V for loudspeaker drivers
3.0~3.3V for others
- 2.5~5.5V tolerant input interface
- Loudspeaker power
3.5W into 4Ω load @ 0dB 1kHz sinewave input
2.0W into 8Ω load @ 0dB 1kHz sinewave input
- Loudspeaker power efficiency (η)
86% for 4Ω @ 0dB 1kHz sinewave input
91% for 8Ω @ 0dB 1kHz sinewave input
- Headphone power
35mW into 32Ω @ 1kHz and 1% THD+N
65mW into 16Ω @ 1kHz and 1% THD+N
113mW into 8Ω @ 1kHz and 1% THD+N
- Volume control for loudspeakers
53steps: +6~-34dB(1dB/step)-36~-58dB(2dB/step)
- Mute function
- Power down function
- Anti-pop design
- Over-temperature protection
- Under-voltage shutdown
- Short-circuit detection

Applications

- CD and DVD
- TV audio
- Internet audio
- USB speaker
- MP3
- Headphone Amplifier
- PDA
- Portable / Handheld
- Mobile phone
- Car audio

Description

This is a stereo digital audio amplifier with high power efficiency, which leads to longer battery life, less heat sink requirement, smaller board size and lower system cost. AD82550 can detect headphone connection and choose to drive either stereo loudspeakers or stereo headphones. Operating with 3.0/3.3/5V loudspeaker driver supply, each loudspeaker channel can typically deliver 0.8/1.0/2.3W to a 4Ω loudspeaker, respectively, with less than 1% THD+N. Operating with 3.0/3.3V headphone driver supply, each headphone channel can typically deliver 29/35mW to 32Ω, 54/65mW to 16Ω and 94/113mW to 8Ω, respectively, with less than 1% THD+N.

Functional Block Diagram

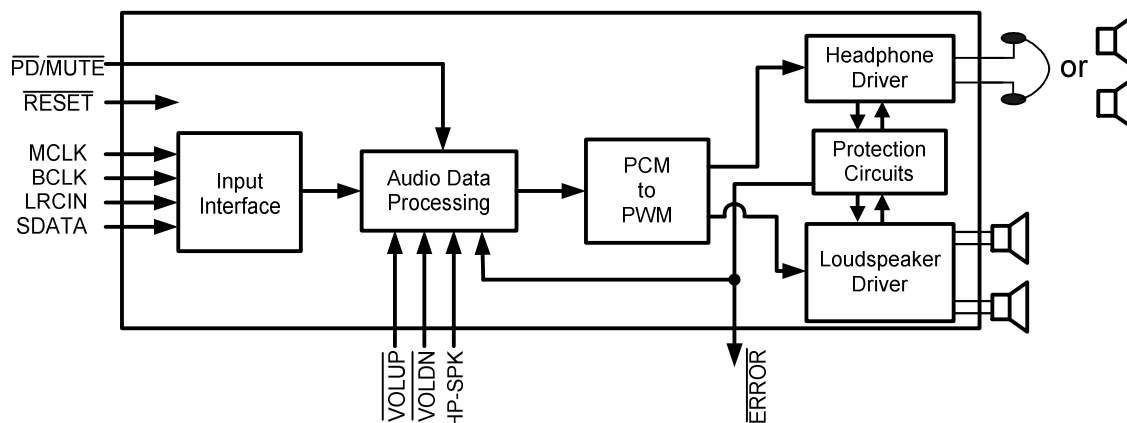

* Advanic reserves the right to change or discontinue this product without notice.

Pin Assignment

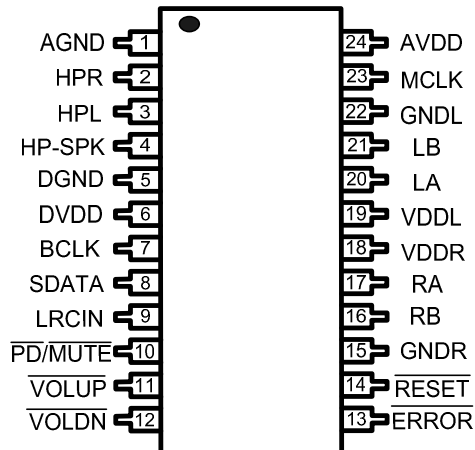

Pin Description

Pin	Name	Type	Description	Characteristics
1	AGND	P	Analog ground	
2	HPR	O	Headphone right channel output	
3	HPL	O	Headphone left channel output	
4	HP-SPK	I	Headphone/loudspeaker switch	5V tolerant Schmitt trigger input with a 380K Ω pull-up resistor (Note 1)
5	DGND	P	Digital ground	
6	DVDD	P	Digital supply	
7	BCLK	I	Bit clock (64Fs) input	5V tolerant Schmitt trigger TTL input buffer
8	SDATA	I	Serial audio data input	5V tolerant Schmitt trigger TTL input buffer
9	LRCIN	I	Left/right sampling clock (Fs) input	5V tolerant Schmitt trigger TTL input buffer
10	$\overline{\text{PD/MUTE}}$	I	Power-down and mute, low active	5V tolerant Schmitt trigger TTL input buffer
11	$\overline{\text{VOLUP}}$	I	Volume up, low active	5V tolerant Schmitt trigger TTL input buffer (Note1)
12	$\overline{\text{VOLDN}}$	I	Volume down, low active	5V tolerant Schmitt trigger TTL input buffer (Note1)
13	$\overline{\text{ERROR}}$	O	Error output	Open-drain output
14	$\overline{\text{RESET}}$	I	Reset, low active	5V tolerant Schmitt trigger TTL input buffer
15	GNDR	P	Ground for loudspeaker right channel	
16	RB	O	Loudspeaker right channel output (-)	
17	RA	O	Loudspeaker right channel output (+)	
18	VDDR	P	Supply for loudspeaker right channel	
19	VDDL	P	Supply for loudspeaker left channel	
20	LA	O	Loudspeaker left channel output (+)	
21	LB	O	Loudspeaker left channel output (-)	
22	GNDL	P	Ground for loudspeaker left channel	
23	MCLK	I	Master clock (256Fs) input	5V tolerant Schmitt trigger TTL input buffer
24	AVDD	P	Analog supply	

Note1: May become bi-directional with less than 30 μ A output current when " $\overline{\text{RESET}}$ " pin is low.

* Advanic reserves the right to change or discontinue this product without notice.

Absolute Maximum Ratings

Symbol	Parameter	Min	Max	Units
DVDD	Supply for Digital Circuit	0	3.6	V
AVDD	Supply for Analog Circuit	0	3.6	V
VDDL(R)	Supply for Left (Right) Channel	0	5.5	V
V_i	Input Voltage	-0.3	5.5	V
T_{stg}	Storage Temperature	-45	150	°C
T_a	Ambient Operating Temperature	-40	85	°C
	Voltage Difference between V_{DDL} and V_{DDR}	-1	1	V
	Voltage Difference between $V_{DDL}(V_{DDR})$ and DVDD/AVDD	-3	3	V
	$V_{DDL}(V_{DDR})$ Power-on Voltage Ramp		0.2	V/ μ s

Recommended Operating Conditions

Symbol	Parameter	Typ	Units
DVDD	Supply for Digital Circuit	3.0~3.3	V
AVDD	Supply for Analog Circuit	3.0~3.3	V
VDDL(R)	Supply for Driver Stage	3.0~5.0	V
T_a	Ambient Operating Temperature	-10~70	°C

Digital Characteristics

Symbol	Parameter	Min	Typ	Max	Units
V_{IH}	High-Level Input Voltage	2.0			V
V_{IL}	Low-Level Input Voltage			0.8	V
V_{OH}	High-Level Output Voltage	2.4			V
V_{OL}	Low-Level Output Voltage			0.4	V
C_i	Input Capacitance		6.4		pF

General Electrical Characteristics

Symbol	Parameter	Condition	Min	Typ	Max	Units
I_{PD}	Supply Current during Power Down			36		μ A
	Junction Temperature for Driver Shutdown			150		°C
	Temperature Hysteresis for Recovery from Shutdown			20		°C
UV_H	Under Voltage Disabled (For AVDD)			2.8		V
UV_L	Under Voltage Enabled (For AVDD)			2.7		V
Fsw	Switching Rate of Loudspeakers and Headphones		8Fs	8Fs	8Fs	Hz
T_{PWM}	Minimum PWM pulse width		$\frac{1}{256Fs}$	$\frac{1}{256Fs}$	$\frac{1}{256Fs}$	Sec
R_{SC}	Loudspeaker Short-Circuit Detection (Note2)	VDDR(L)=5V		3.0	3.4	Ω
R_{SCH}	Headphone Output Short-Circuit Detection	Steady State		3.0	3.4	Ω

Note2: Loudspeaker short-circuit protection is effective when external LC or ferrite bead filters are properly used. Long time short-circuit will result in reduced device reliability.

Package Options

Package Type	Part Number	Thermal Information
24L SSOP 209mil	AD8255TC	$\theta_{JA} = 64.7$ °C/W (Condition: still air, multilayer board)
24L SOP 300mil	AD8255SC	$\theta_{JA} = 80.2$ °C/W (Condition: still air, multilayer board)

* Advanic reserves the right to change or discontinue this product without notice.

Electrical Characteristics and Specifications for Loudspeaker

- Condition: DVDD=AVDD=3.3V, VDDL=VDDR=5V, $F_s=48\text{kHz}$, Load= 8Ω with passive LC lowpass filter ($L=22\mu\text{H}$ with $R_{DC}=0.12\Omega$, $C=470\text{nF}$); Input is 1kHz sinewave with the highest volume level. MCLK duty cycle is $50\pm 1\%$.

Symbol	Parameter	Condition	Input Level	Min	Typ	Max	Units
P_{OMAX}	Maximum RMS Output Power		0dB		2.0		W
P_O	RMS Output Power for Each Channel	10% THD+N	-3.6dB		1.7		W
		1% THD+N	-6dB		1.3		W
I_{cc}	Required RMS Supply Current		-9dB		0.29		A
THD+N	Total Harmonic Distortion+Noise	$P_o=40\text{mW}$	-21dB		0.06		%
SNR	Signal to Noise Ratio(Note3)	$P_o=1.0\text{W}$	-7dB		98		dB
DR	Dynamic Range(Note3)		-60dB		106		dB
PSRR	Power Supply Rejection Ratio		-66dB		60		dB
	Channel Separation		-7dB		82		dB
η	Efficiency	$P_o=2.0\text{W}$	0dB		91		%

Note3: Measured with A-weighting filter

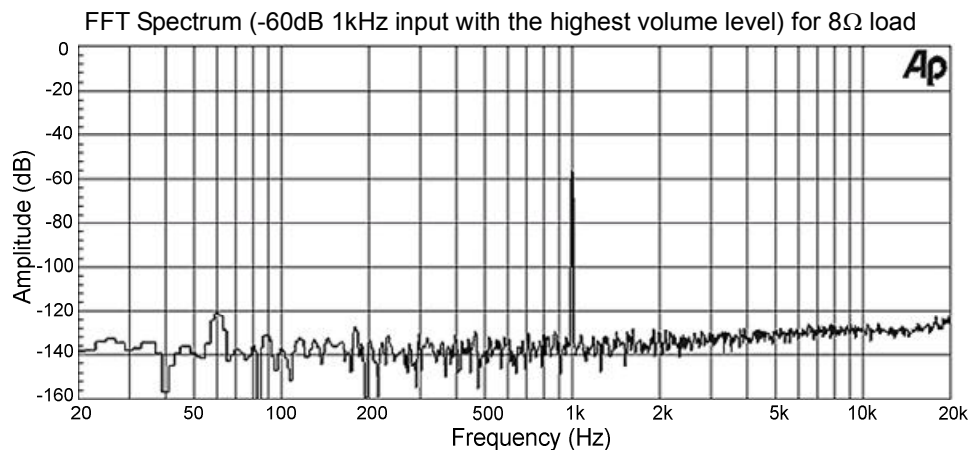

Efficiency v.s. Output Power

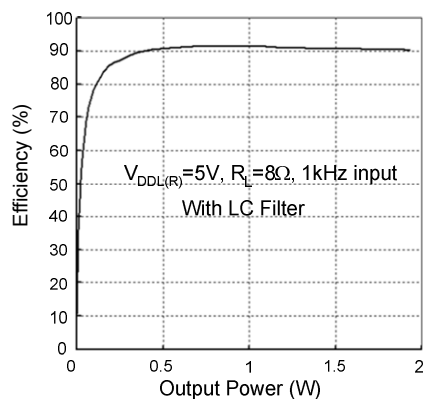

THD+N v.s. Output Power (1kHz input with 8Ω load)

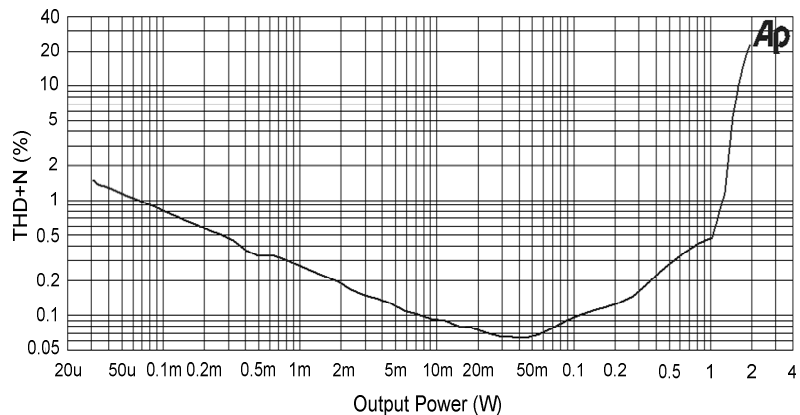

* Advanic reserves the right to change or discontinue this product without notice.

- Condition: DVDD=AVDD=3.3V, VDDL=VDDR=5V, $F_s=48\text{kHz}$, Load= 4Ω with passive LC lowpass filter ($L=10\mu\text{H}$ with $R_{DC}=0.12\Omega$, $C=1000\text{nF}$); Input is 1kHz sinewave with the highest volume level. MCLK duty cycle is $50\pm 1\%$.

Symbol	Parameter	Condition	Input Level	Min	Typ	Max	Units
P_{OMAX}	Maximum RMS Output Power		0dB		3.5		W
P_o	RMS Output Power for Each Channel	10% THD+N	-3.6dB		2.9		W
		1% THD+N	-6dB		2.3		W
I_{cc}	Required RMS Supply Current		-9dB		0.52		A
THD+N	Total Harmonic Distortion+Noise	$P_o=25\text{mW}$	-25dB		0.06		%
SNR	Signal to Noise Ratio(Note4)	$P_o=1.8\text{W}$	-7dB		95		dB
DR	Dynamic Range(Note4)		-60dB		103		dB
PSRR	Power Supply Rejection Ratio		-66dB		60		dB
	Channel Separation		-7dB		82		dB
η	Efficiency	$P_o=3.5\text{W}$	0dB		86		%

Note4: Measured with A-weighting filter

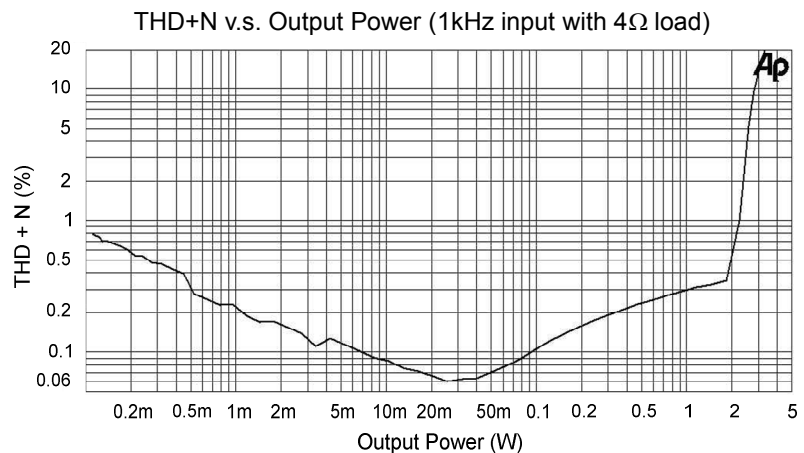
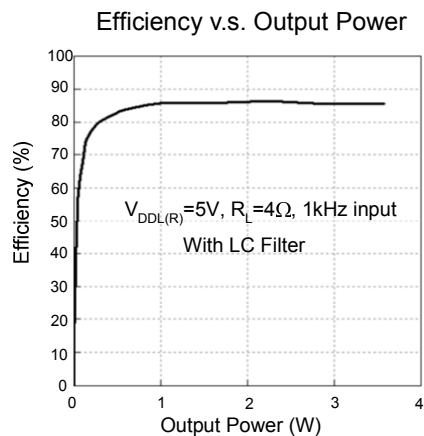
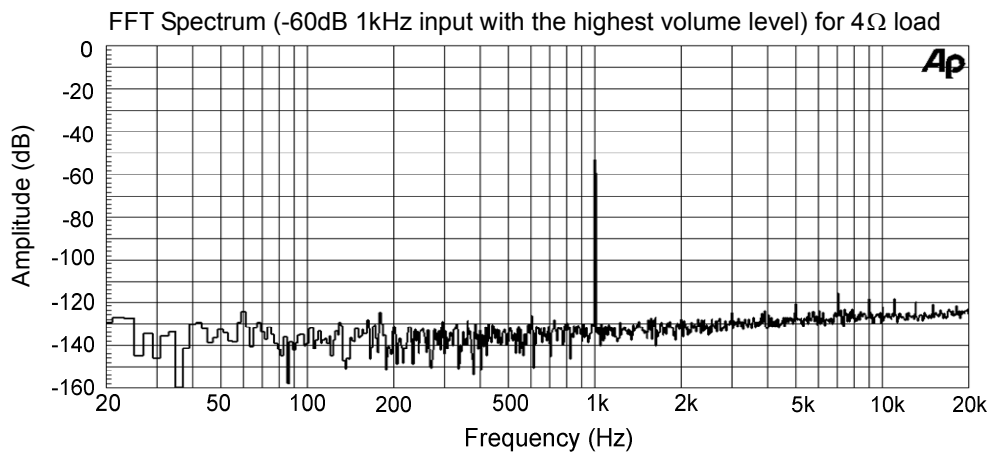

* Avanic reserves the right to change or discontinue this product without notice.

Electrical Characteristics and Specifications for Headphone

- Condition: DVDD=AVDD=3.3V, $F_s=48\text{kHz}$, Load= 32Ω with DC decoupling capacitor ($C_{DC}=100\mu\text{F}$) and passive LC lowpass filter ($L=220\mu\text{H}$, $C=0.068\mu\text{F}$); Input is 1kHz sinewave with the highest volume level. MCLK duty cycle is $50\pm 1\%$.

Symbol	Parameter	Condition	Input Level	Min	Typ	Max	Units
P_o	RMS Output Power for Each Channel		0dB		35		mW
I_{cc}	Required Supply Current	2 channels	-9dB		10		mA
THD+N	Total Harmonic Distortion+Noise	$P_o=1\text{mW}$			0.05		%
SNR	Signal to Noise Ratio(Note5)	$P_o=26\text{mW}$	-1.3dB		87		dB
DR	Dynamic Range(Note5)		-60dB		96		dB
	Channel Separation		-1.3dB		64		dB
η	Efficiency	$P_o=35\text{mW}$	0dB		72		%

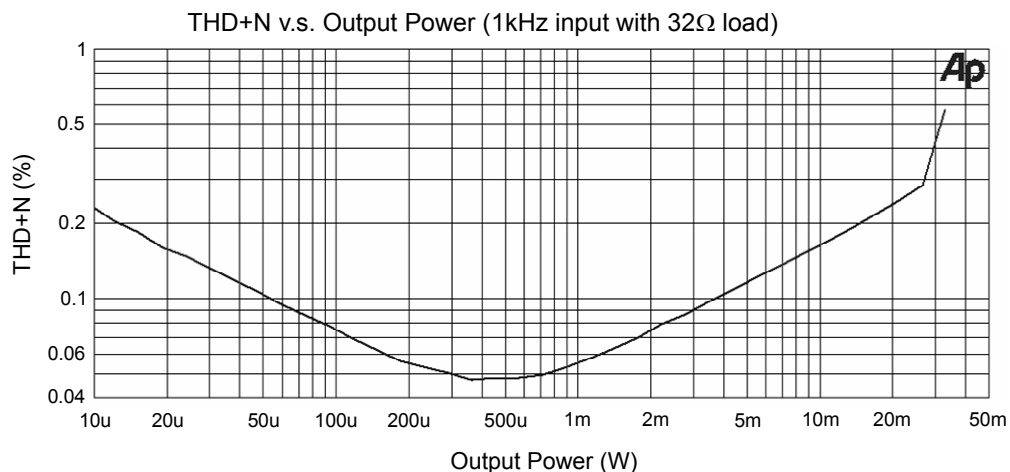
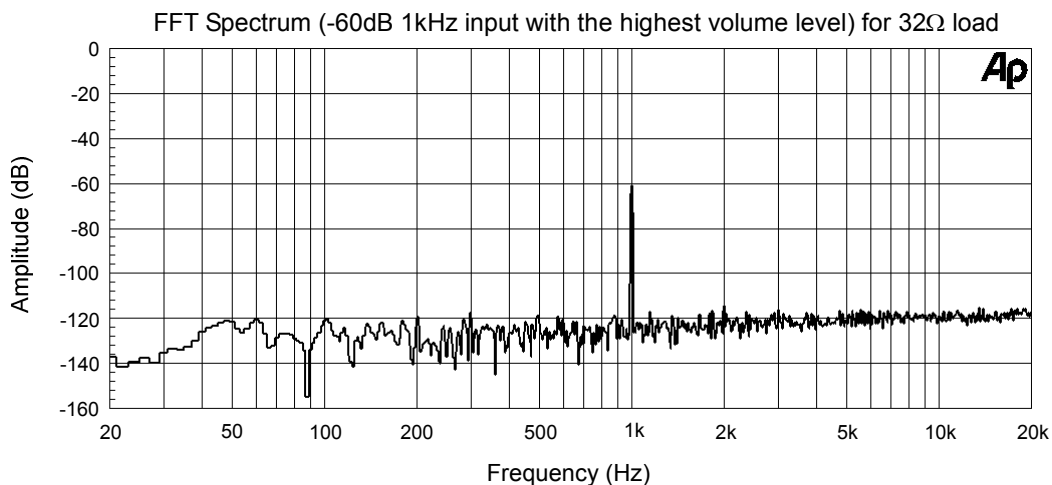

* Advanic reserves the right to change or discontinue this product without notice.

- Condition: DVDD=AVDD=3.3V, $F_S=48\text{kHz}$, Load= 16Ω with DC decoupling capacitor ($C_{DC}=220\mu\text{F}$) and passive LC lowpass filter ($L=100\mu\text{H}$, $C=0.15\mu\text{F}$); Input is 1kHz sinewave with the highest volume level. MCLK duty cycle is $50\pm 1\%$.

Symbol	Parameter	Condition	Input Level	Min	Typ	Max	Units
P_o	RMS Output Power for Each Channel		0dB		65		mW
I_{cc}	Required Supply Current	2 channels	-9dB		13		mA
THD+N	Total Harmonic Distortion+Noise	$P_o=2\text{mW}$			0.04		%
SNR	Signal to Noise Ratio(Note5)	$P_o=49\text{mW}$	-1.3dB		83		dB
DR	Dynamic Range(Note5)		-60dB		97		dB
	Channel Separation		-1.3dB		60		dB
η	Efficiency	$P_o=65\text{mW}$	0dB		78		%

- Condition: DVDD=AVDD=3.3V, $F_S=48\text{kHz}$, Load= 8Ω with DC decoupling capacitor ($C_{DC}=470\mu\text{F}$) and passive LC lowpass filter ($L=47\mu\text{H}$, $C=0.33\mu\text{F}$); Input is 1kHz sinewave with the highest volume level. MCLK duty cycle is $50\pm 1\%$.

Symbol	Parameter	Condition	Input Level	Min	Typ	Max	Units
P_o	RMS Output Power for Each Channel		0dB		113		mW
I_{cc}	Peak Supply Current	2 channels	-9dB		20		mA
THD+N	Total Harmonic Distortion+Noise	$P_o=4\text{mW}$			0.1		%
SNR	Signal to Noise Ratio(Note5)	$P_o=82\text{mW}$	-1.3dB		80		dB
DR	Dynamic Range(Note5)		-60dB		97		dB
	Channel Separation		-1.3dB		55		dB
η	Efficiency	$P_o=113\text{mW}$	0dB		80		%

Note5: Measured with A-weighting filter

* Advanic reserves the right to change or discontinue this product without notice.

Interface Configuration

- I²S

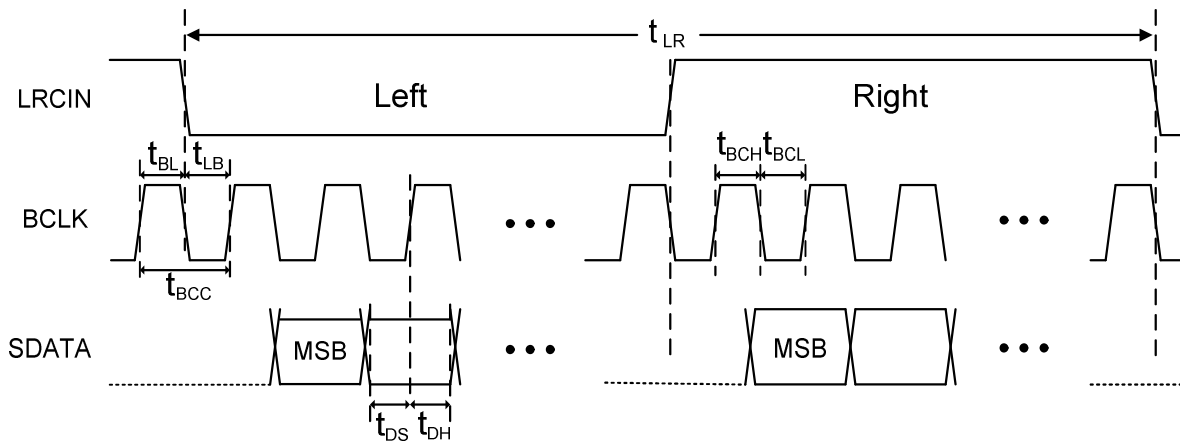

Symbol	Parameter	Min	Typ	Max	Units
t_{LR}	LRCIN Period ($1/F_S$)	10.41		125	μs
t_{BL}	BCLK Rising Edge to LRCIN Edge	50			ns
t_{LB}	LRCIN Edge to BCLK Rising Edge	50			ns
t_{BCC}	BCLK Period ($1/64F_S$)	162.76		1953	ns
t_{BCH}	BCLK Pulse Width High	81.38		976.5	ns
t_{BCL}	BCLK Pulse Width Low	81.38		976.5	ns
t_{DS}	SDATA Set-Up Time	50			ns
t_{DH}	SDATA Hold Time	50			ns

- System Clock Timing

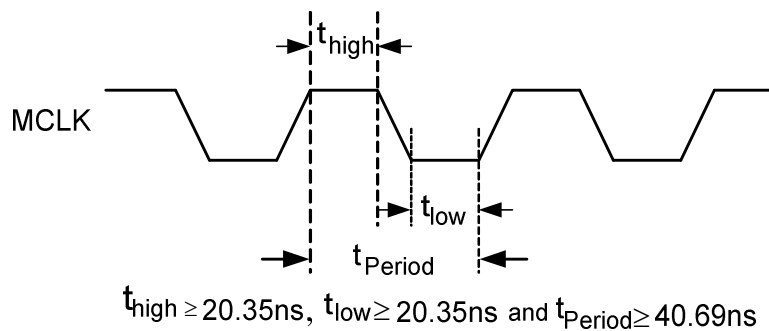

* Advanic reserves the right to change or discontinue this product without notice.

Operation Descriptions

- Volume control

Audio volume can be increased or decreased by sending a high→low→high transition pulse to VOLUP pin or VOLDN pin, respectively. The volume range is from +6dB to -58dB for loudspeakers and 0dB to -64dB for headphones, respectively. The default volume levels are -18dB for loudspeaker and -24dB for headphone, respectively. The volume control timing diagram is shown below where $t_1 \geq (10/F_s)$, $t_2 \geq (2/F_s)$ and $F_s = 8\text{KHz} \sim 96\text{KHz}$.

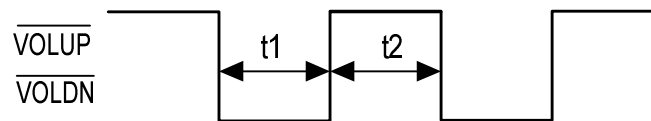

Two kinds of volume level control example are described below. Other choices can be user-defined depending on users' control.

(i) 53-step

AD82550 has 53 volume levels. Volume levels 0~40 have the step size of 1dB/step (+6dB, +5dB, +4dB ..., -33dB, -34dB for loudspeaker and 0dB, -1dB, -2dB ..., -39dB, -40dB for headphone). Volume levels 41~52 have the step size of 2dB/step (-36dB, -38dB, -40dB..., -56dB, -58dB for loudspeaker and -42dB, -44dB, -46dB..., -62dB, -64dB for headphone).

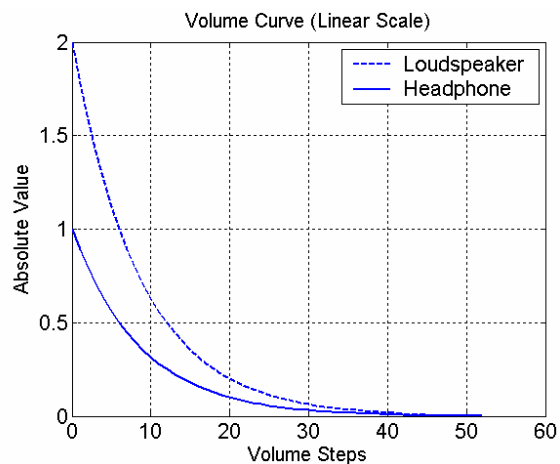
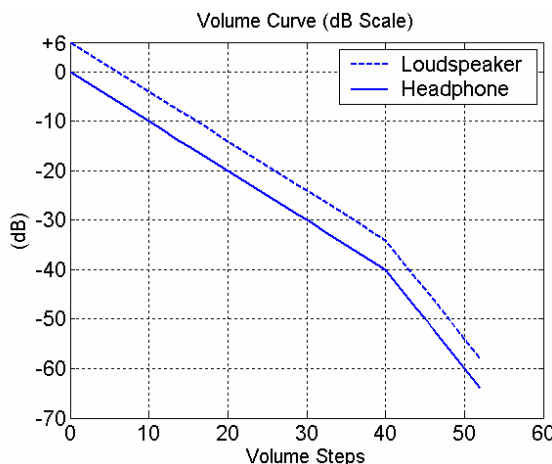

(ii) 33-step

Linearization of the volume levels in dB scale can be done via external control. The original volume levels 0~40 (1dB/step) can be mapped to new volume levels 0~20

* Advanic reserves the right to change or discontinue this product without notice.

(2dB/step), and the original volume levels 41~52 (2dB/ step) can be mapped to new volume levels 21~32 (2dB/step). The compressed volume levels 0~32 becomes +6 dB, +4 dB, ..., -56 dB, -58dB for loudspeaker and 0 dB, -2 dB, ..., -62 dB, -64dB for headphone, respectively.

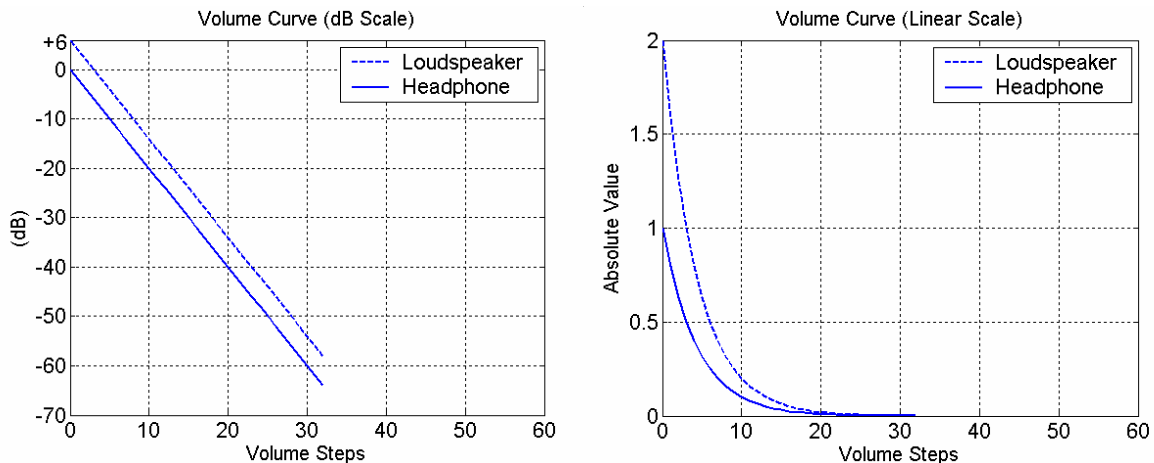

- Volume gain

The highest volume gain is 6dB for loudspeaker (0dB for headphone), referred to the original input signal level.

- Reset

When the level of $\overline{\text{RESET}}$ pin is low, AD82550 will clear the data of internal storage elements and set the default volume level. The default volume level is -18dB for loudspeaker (-24dB for headphone).

AD82550 will exit reset state at the third LRCIN clock after $\overline{\text{RESET}}$ pin becomes high.

- Power down (PD) and mute control

AD82550 has build-in volume fade-in/fade-out design for PD/mute function. The relative PD/mute timing diagrams for loudspeakers are shown below.

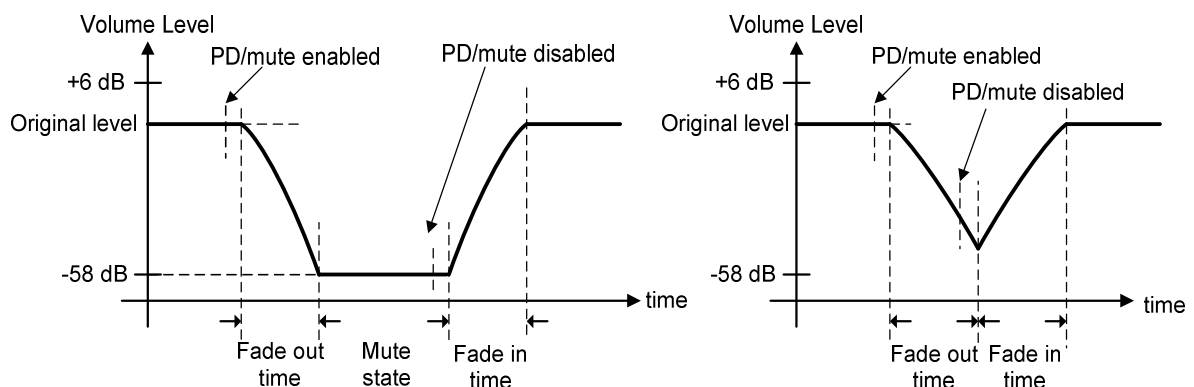

* Advanic reserves the right to change or discontinue this product without notice.

AD82550 will detect $\overline{\text{PD/MUTE}}$ pin once an LRCIN cycle. When AD82550 detects 9 consecutive zeros, it will execute a fade-out procedure. The volume level will be decreased to -58 dB for loudspeakers (-64dB for headphones) in several LRCIN cycles. Once the fade-out procedure is finished, AD82550 will turn off the power stages, stop clock signals (MCLK, BCLK, LRCIN) from feeding into digital circuits and turn off the current bias of the internal analog circuits. After $\overline{\text{PD/MUTE}}$ pin is pulled low, AD82550 needs up to 75 LRCIN clocks to finish the above works before entering power down state. Functions of volume up and volume down will be disabled when PD/mute function is enabled.

When AD82550 detects 9 consecutive ones from the $\overline{\text{PD/MUTE}}$ pin, the PD/mute function will be disabled and a fade-in procedure is then executed. If the PD/mute function is disabled in the midway of the fade-out procedure, AD82550 will also execute the fade-in procedure. The volume level will return to that before the PD/mute function is enabled. In addition, AD82550 will establish the analog circuits' bias current and feed the clock signals (MCLK, BCLK, LRCIN) into the digital circuits. Then, AD82550 will return to its operation without power down.

- Self-protection circuits (Typical values are used below.)

AD82550 has build-in thermal, short-circuit and under-voltage detection circuits.

- (i) If the internal junction temperature is higher than 150°C, loudspeaker and headphone power stages will be turned off and the temperature hysteresis for AD82550 to return to normal operation is about 20°C. The temperature values can have around 10% variation.
- (ii) To protect loudspeaker and headphone power stages when the lines connected to loudspeakers (or the lines connected to headphones) are shorted each other or to GND, circuits for the detection of output loading are built in the AD8255. For normal operation, loudspeaker resistance larger than 3.4Ω and headphone resistance larger than 3.4Ω are required. Otherwise, short-circuit detectors may pull the $\overline{\text{ERROR}}$ pin to DGND. To effectively protect AD82550 from short-circuit accidents, the $\overline{\text{ERROR}}$ pin and $\overline{\text{RESET}}$ pin are suggested to connect together. Once short-circuit condition exists, the $\overline{\text{ERROR}}$ pin will be pulled to DGND and AD82550 is then reset. The recommended R and C values for the RC network connected to the $\overline{\text{RESET}}$ pin are 10MΩ and 10nF, respectively. The capacitance should be close to 10nF as possible. When VDDR(L) is larger than 3.6V, loudspeaker short-circuit protection is reliable only when LC or ferrite bead filters are properly used.
- (iii) Once the AVDD voltage is lower than 2.7V, AD82550 will turn off its loudspeaker and headphone power stages and cease the operation of digital processing circuits.

* Advanic reserves the right to change or discontinue this product without notice.

When AVDD becomes larger than 2.8V, AD82550 will return to normal operation.

- Anti-pop design

AD82550 is with anti-pop design. Annoying pop sounds are suppressed during initial power on, power down/up, mute, power off and volume level change. When one of the operations mentioned above is applied, AD82550 will internally generate appropriate control signals to suppress pop sounds.

- Loudspeaker and headphone switching

AD82550 can switch between headphone and loudspeaker modes automatically with the application circuits shown in the application circuit section. When HP-SPK pin is pulled high, AD82550 will enter headphone mode and loudspeaker output will be muted. When HP-SPK pin is pulled low, AD82550 will enter loudspeaker mode and headphone will be muted. HP-SPK pin is connected to DVDD via a 380K Ω (typical value) resistor in the chip.

- Digital filter frequency response

The overall inband gain ripple is approximately within ± 0.1 dB.

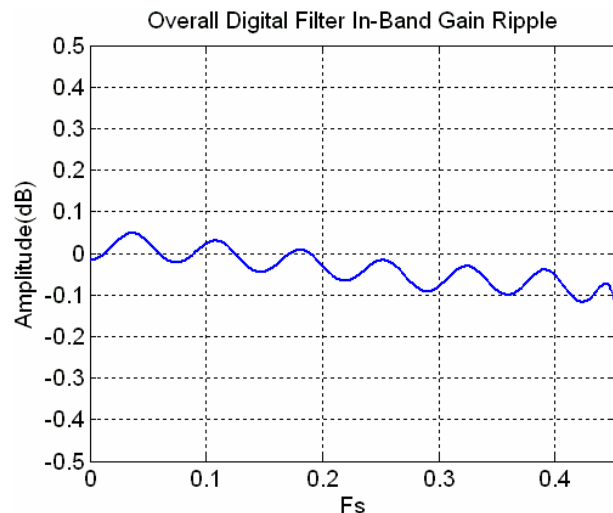
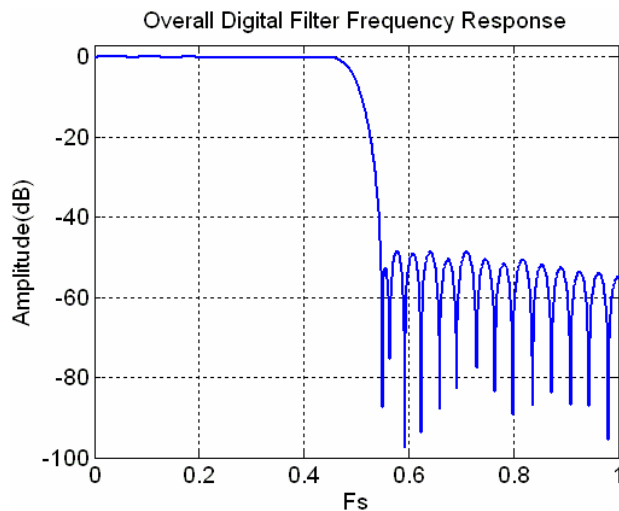

* Advanic reserves the right to change or discontinue this product without notice.

Package Dimensions

- 24L SSOP (209mil) Package

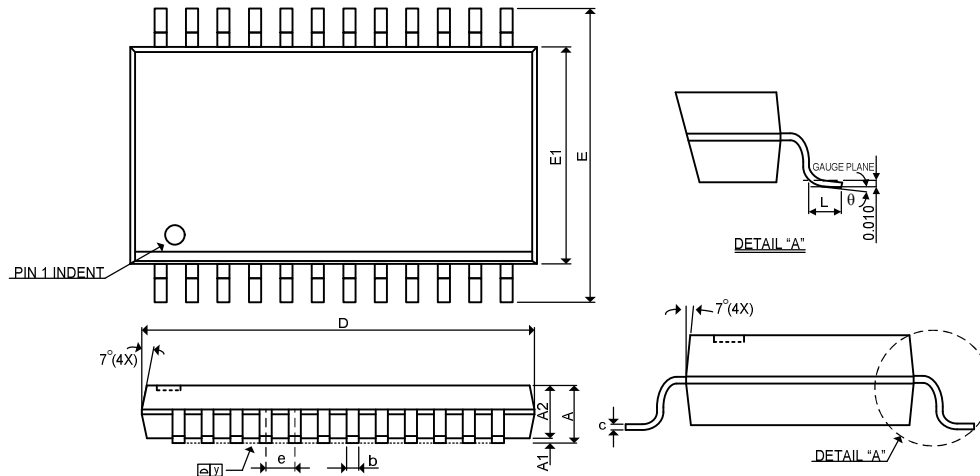

SYMBOLS	DIMENSIONS IN MILLIMETERS			DIMENSIONS IN MILS		
	MIN	NOM	MAX	MIN	NOM	MAX
A	-	-	2.0	-	-	79
A1	0.05	-	-	2	-	-
A2	1.65	1.75	1.85	65	69	73
b	0.22	-	0.38	9	-	15
C	0.09	-	0.25	4	-	10
D	7.90	8.20	8.50	311	323	345
E	7.40	7.80	8.20	291	307	323
E1	5.00	5.30	5.60	197	209	220
e	0.65 BSC			26 BSC		
L	0.55	0.75	0.95	22	30	37
θ	7° TYP			7° TYP		
y	-	-	0.1	-	-	4

* Advanic reserves the right to change or discontinue this product without notice.

● 24L SOP (300mil) Package

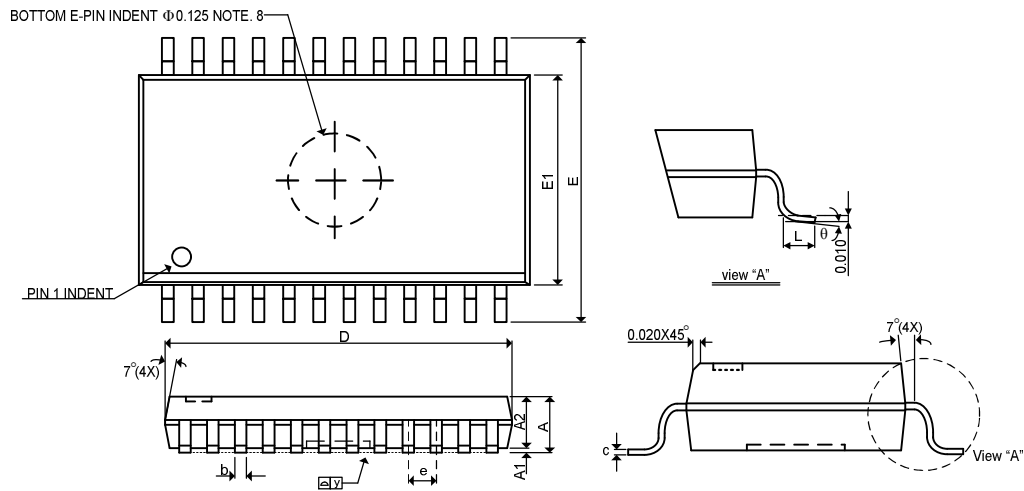

SYMBOLS	DIMENSIONS IN MILLIMETERS			DIMENSIONS IN INCHES		
	MIN	NOM	MAX	MIN	NOM	MAX
A	2.36	2.51	2.64	0.093	0.099	0.104
A1	0.10	-	0.30	0.004	-	0.012
A2	-	2.34	-	-	0.092	-
b	-	0.41	-	-	0.016	-
C	-	0.25	-	-	0.010	-
D	15.21	15.24	15.60	0.599	0.600	0.614
E	10.01	10.31	10.64	0.394	0.406	0.419
E1	7.39	7.49	7.59	0.291	0.295	0.299
e	-	1.27	-	-	0.050	-
L	0.40	0.89	1.27	0.016	0.035	0.050
y	-	-	0.102	-	-	0.004
θ	0°	-	8°	0°	-	8°

* Advanic reserves the right to change or discontinue this product without notice.