



Regulated 5V Charge Pump In SOT-23

FEATURES

- Regulated $\pm 4\%$ Output Voltage
- Output Current: 110mA ($V_{IN} = 3.3V$)
180mA ($V_{IN} = 3.6V$)
- Input Range: 2.7V to 5.0V
- No Inductors Required
- Very Low Shutdown Current: $< 1\mu A$
- 1.8MHz Switching Frequency
- Short-Circuit and Over Temperature Protection
- Low Profile Package: SOT-23-6

APPLICATIONS

- White LEDs Backlighting
- SIM Interface Supplies for Cellular Telephones
- Li-Ion Battery Backup Supplies
- Local 3V to 5V Conversion
- Smart Card Readers
- PCMCIA Local 5V Supplies

DESCRIPTION

The AIC1848 charge pump is a micropower charge pump DC/DC converter that produces a regulated output voltage from 2.7V to 5.0V input voltage. Low external-part count (one $0.1\mu F$ flying capacitor and two small bypass capacitors) make the AIC1848 ideal for small, battery-powered applications.

The AIC1848 operates as a PWM (Pulse Width Modulation) mode switched capacitor voltage doubler to produce a regulated output and features with thermal shutdown capability and short circuit protection.

The AIC1848 is available in a space-saving SOT-23-6 package.

TYPICAL APPLICATION CIRCUIT

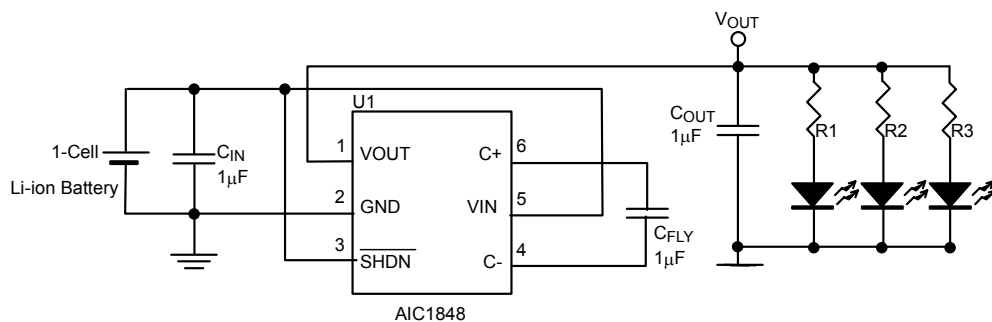

Regulated 5V Output from 2.7V to 5.0V Input

WLED series number: NSPW310BS, $V_F = 3.6V$, $I_F = 20mA$

$$R = \frac{V_{OUT} - V_F}{I_F}$$

C_{IN} , C_{FLY} , C_{OUT} : JMK107BJ105KA, TAIYO YUDEN

C_{FLY} : EMK107BJ104KA, TAIYO YUDEN



ORDERING INFORMATION

AIC1848-XXXX

PACKING TYPE
 TR: TAPE & REEL
 BG: BAG

 PACKAGE TYPE
 G: SOT-23-6

 C: COMMERCIAL
 P: LEAD FREE COMMERCIAL

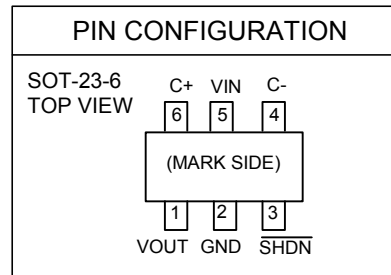

Example: AIC1848CGTR
 → in SOT-23-6 Package & Taping & Reel Packing Type
 AIC1848PGTR
 → in SOT-23-6 Lead Free Package & Taping & Reel Packing Type

SOT-23-6 Marking

| Part No. | Marking | Part No. | Marking |
|-----------|---------|-----------|---------|
| AIC1848CG | BP50 | AIC1848PG | BP50P |

ABSOLUTE MAXIMUM RATINGS

| | |
|--|-----------------|
| VIN to GND | 6V |
| VOUT to GND | 6V |
| All Other Pins to GND | 6V |
| VOUT Short-Circuit Duration | Continuous |
| Operating Temperature Range | -40°C to 85 °C |
| Maximum Operation Junction Temperature | 125°C |
| Storage Temperature Range | -65°C to 150 °C |
| Lead Temperature (Soldering 10 Sec.) | 260°C |

Absolute Maximum Ratings are those values beyond which the life of a device may be impaired.

■ TEST CIRCUIT

Refer to Typical Application Circuit.

■ ELECTRICAL CHARACTERISTICS

($T_A=25^\circ\text{C}$, $C_{FLY}=1\mu\text{F}$, $C_{IN}=1\mu\text{F}$, $C_{OUT}=1\mu\text{F}$, unless otherwise specified.) (Note 1)

| PARAMETER | TEST CONDITIONS | SYMBOL | MIN. | TYP. | MAX. | UNIT |
|---------------------------------|--|------------------------------|------|------|-----------|---------------|
| Input Voltage | | V_{IN} | 2.7 | | V_{OUT} | V |
| Output Voltage | $2.7\text{V} \leq V_{IN} < 3.3\text{V}$, $I_{OUT} \leq 40\text{mA}$ | V_{OUT} | -4 | | +4 | % |
| | $3.3\text{V} \leq V_{IN} \leq 5.0\text{V}$, $I_{OUT} \leq 100\text{mA}$ | | -4 | | +4 | |
| Continuous Output Current | $V_{IN}=3\text{V}$, $V_{OUT}=5.0\text{V}$ $\overline{\text{SHDN}}=V_{IN}$ | I_{OUT} | 60 | | | mA |
| Supply Current | $2.7\text{V} \leq V_{IN} \leq 5.0\text{V}$, $I_{OUT}=0$, $\overline{\text{SHDN}}=V_{IN}$ | I_{CC} | 2 | 2.5 | 3 | mA |
| Shutdown Current | $2.7\text{V} \leq V_{IN} \leq 5.0\text{V}$, $I_{OUT}=0$, $\overline{\text{SHDN}}=0\text{V}$ | $I_{\overline{\text{SHDN}}}$ | | 0.01 | 1.0 | μA |
| Efficiency | $V_{IN}=2.7\text{V}$, $I_{OUT}=30\text{mA}$ | η | | 85 | | % |
| Switching Frequency | Oscillator Free Running | f_{OSC} | | 1.8 | | MHz |
| Shutdown Input Threshold (High) | | V_{IH} | 1.4 | | | V |
| Shutdown Input Threshold (Low) | | V_{IL} | | | 0.3 | V |
| Shutdown Input Current (High) | $\overline{\text{SHDN}}=V_{IN}$ | I_{IH} | -1 | | 1 | μA |
| Shutdown Input Current (Low) | $\overline{\text{SHDN}}=0\text{V}$ | I_{IL} | -1 | | 1 | μA |
| Vout Turn On Time | $V_{IN}=3\text{V}$, $I_{OUT}=1\text{mA}$ | t_{ON} | | 50 | | μS |
| Output Short Circuit Current | $V_{IN}=3\text{V}$, $V_{OUT}=0\text{V}$, $\overline{\text{SHDN}}=V_{IN}$ | I_{SC} | | 300 | | mA |

Note 1: Specifications are production tested at $T_A=25^\circ\text{C}$. Specifications over the -40°C to 85°C operating temperature range are assured by design, characterization and correlation with Statistical Quality Controls (SQC).

TYPICAL PERFORMANCE CHARACTERISTICS

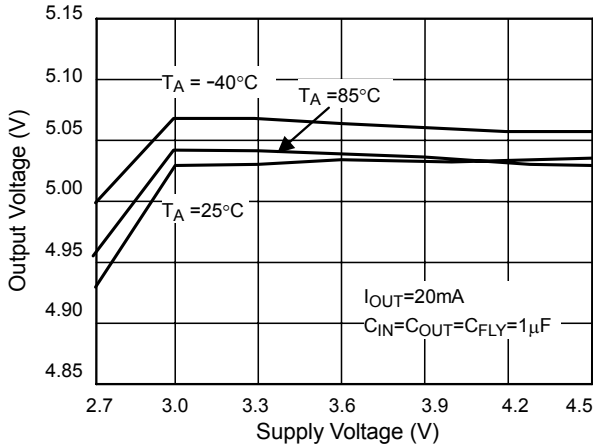

Fig. 1 Output Voltage vs Supply Voltage

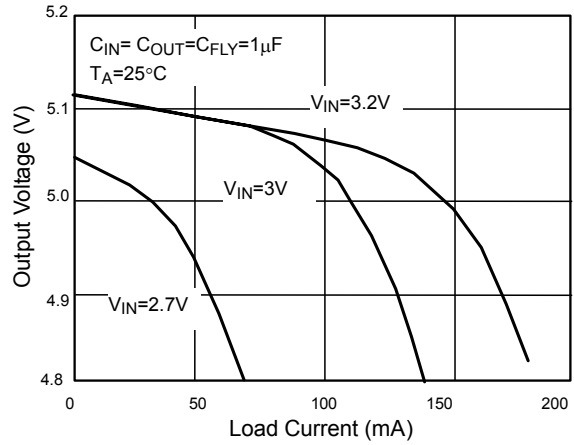

Fig. 2 Output Voltage vs. Load Current

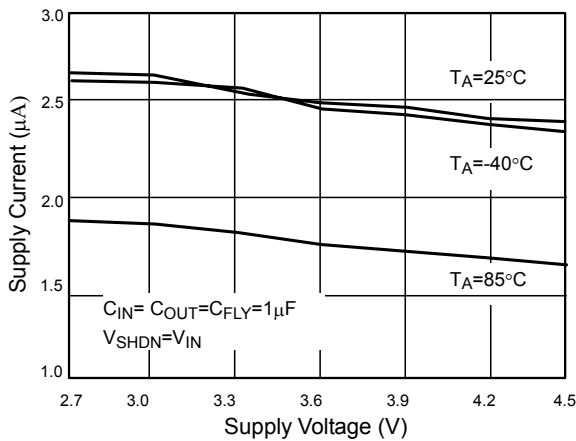

Fig. 3 No Load Supply Current vs. Supply Voltage

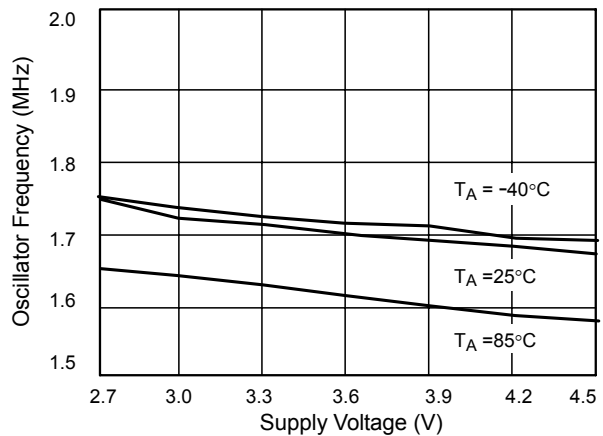

Fig. 4 Oscillator Frequency vs. Supply Voltage

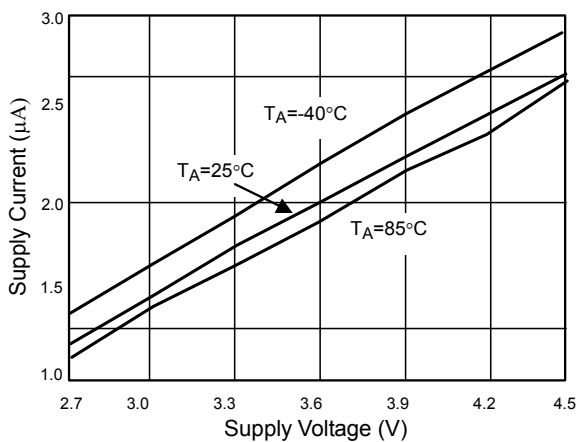

Fig. 5 V_{SHDN} Threshold Voltage vs. Supply Voltage

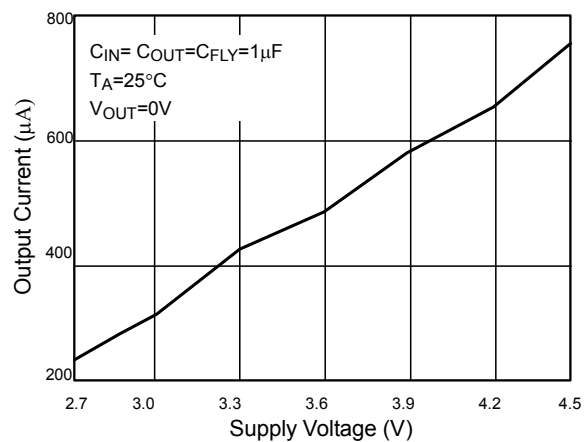

Fig. 6 Short Circuit Current vs. Supply Voltage

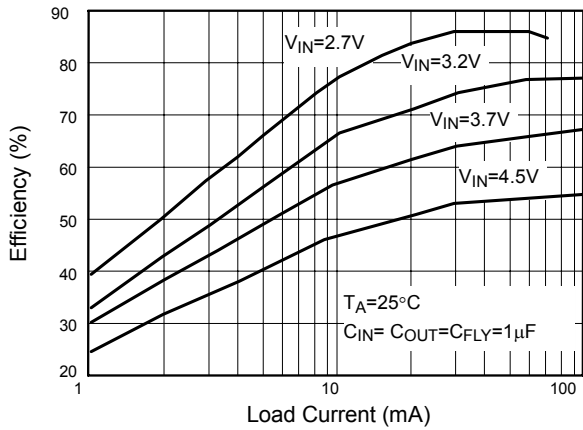

Fig. 7 Efficiency vs. Load Current

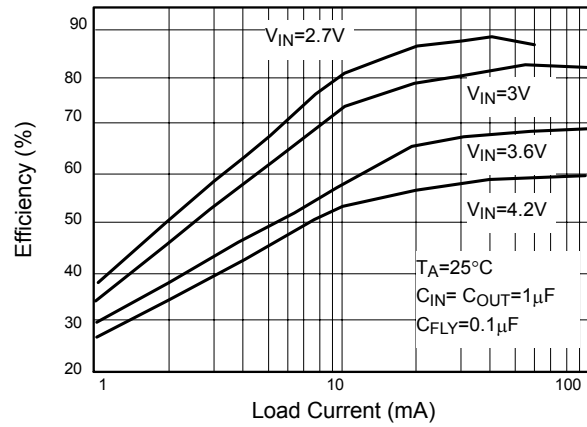

Fig. 8 Efficiency vs. Load Current

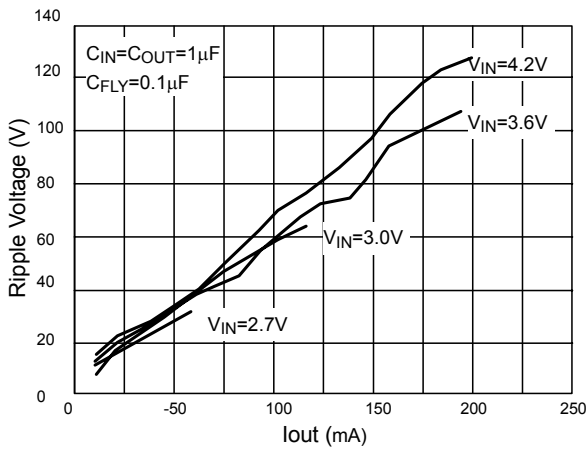
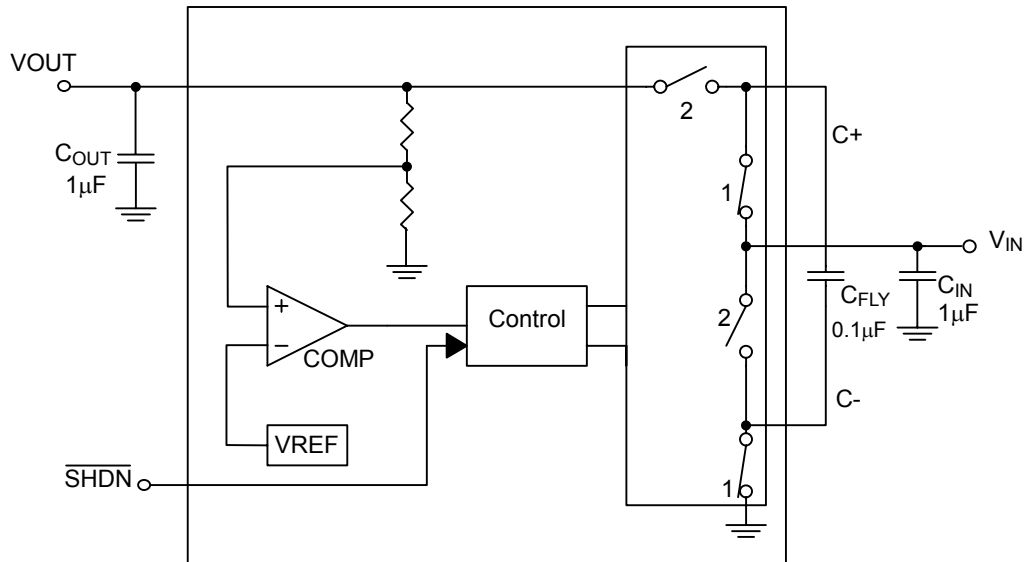

Fig. 9 Ripple Voltage

■ BLOCK DIAGRAM



■ PIN DESCRIPTIONS

- PIN 1: VOUT - Regulated output voltage. For the best performance, V_{OUT} should be bypassed with a 1µF (min) low ESR capacitor with the shortest distance in between.
- PIN 2: GND - Ground. Should be tied to a ground plane for best performance.
- PIN 3: $\overline{\text{SHDN}}$ - Active low shutdown input. A low voltage on $\overline{\text{SHDN}}$ disables the

AIC1848. $\overline{\text{SHDN}}$ is not allowed to float.

- PIN 4: C- - Flying capacitor negative terminal.
- PIN 5: VIN - Input supply voltage. V_{IN} should be bypassed with a 1µF (min) low ESR capacitor.
- PIN 6: C+ - Flying capacitor positive terminal.

■ APPLICATION INFORMATION

Introduction

AIC1848 is a micropower charge pump DC/DC converter that produces a regulated 5V output with an input voltage range from 2.7V to 5.0V. It utilizes the charge pump topology to boost V_{IN} to a regulated output voltage. Regulation is obtained by sensing the output voltage through an internal resistor divider. A switched doubling circuit enables the charge pump when the feedback voltage is lower than the trip point of the internal comparator, and vice versa. When the charge pump is enabled, a two-phase non-overlapping clock activates the charge pump switches.

Operation

This kind of converter uses capacitors to store and transfer energy. Since the capacitors can't change their voltage level abruptly, the voltage ratio of V_{OUT} over V_{IN} is limited to some range. Capacitive voltage conversion is obtained by switching a capacitor periodically. It first charges the capacitor by connecting it across a voltage source and then connects it to the output. Referring to Fig. 10, during the on state of internal clock, Q_1 and Q_4 are closed, which charges C_1 to V_{IN} level. During the off state, Q_3 and Q_2 are closed. The output voltage is V_{IN} plus V_{C1} , that is, $2V_{IN}$.

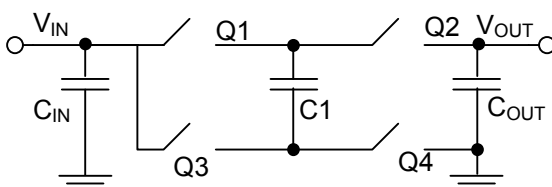

Fig. 10 The circuit of charge pump

Short Circuit/Thermal Protection

AIC1848 owns a built-in short circuit current limiting as well as an over temperature protection. During the short circuit condition, the output current is automatically constrained at approximately 300mA. This short circuit current will cause a rise in the internal IC junction temperature. When the die temperature exceeds 150°C , the thermal protection will shut the charge pump switching operation down and the die temperature will reduce afterwards. Once the die temperature drops below 135°C , the charge pump switching circuit will re-start. If the fault doesn't eliminate, the above protecting operation will repeat again and again. It allows AIC1848 to continuously work at short circuit condition without damaging the device.

Shutdown

In shutdown mode, the output is disconnected from input. The input current gets extremely low since most of the circuitry is turned off. Due to high impedance, shutdown pin can't be floated.

Efficiency

Referring to Fig. 11 and Fig. 12 here shows the circuit of charge pump at different states of operation. R_{DS-ON} is the resistance of the switching element at conduction. ESR is the equivalent series resistance of the flying capacitor C_1 . I_{ON-AVE} and $I_{OFF-AVE}$ are the average current during on state and off state, respectively. D is the duty cycle, which means the proportion the on state takes. Let's take advantage of conservation of charge for capacitor C_1 . Assume that the

capacitor C_1 has reached its steady state. The amount of charge flowing into C_1 during on state is equal to that flowing out of C_1 at off state.

$$I_{ON-AVE} \times DT = I_{OFF-AVE} \times (1-D)T \dots\dots(1)$$

$$I_{ON-AVE} \times D = I_{OFF-AVE} \times (1-D) \dots\dots(2)$$

$$\begin{aligned} I_{IN} &= I_{ON-AVE} \times D + I_{OFF-AVE} \times (1-D) \\ &= 2 \times I_{ON-AVE} \times D \dots\dots(3) \\ &= 2 \times I_{OFF-AVE} \times (1-D) \end{aligned}$$

$$I_{OUT} = I_{OFF-AVE} \times (1-D)$$

$$I_{IN} = 2I_{OUT}$$

For AIC1848, the controller takes the PWM (Pulse Width Modulation) control strategy. When the duty cycle is limited to 0.5, there will be:

$$I_{ON-AVE} \times 0.5 \times T = I_{OFF-AVE} \times (1-0.5) \times T$$

$$I_{ON-AVE} = I_{OFF-AVE}$$

According to the equation (4), we know that as long as the flying capacitor C_1 is at steady state, the input current is twice the output current. The efficiency of charge pump is given below:

$$\eta = \frac{V_{OUT} \times I_{OUT}}{V_{IN} \times I_{IN}} = \frac{V_{OUT} \times I_{OUT}}{V_{IN} \times 2I_{OUT}} = \frac{V_{OUT}}{2V_{IN}} \dots\dots(6)$$

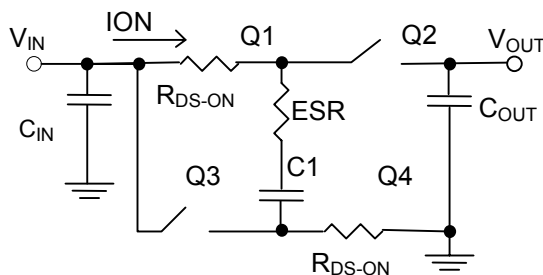

Fig. 11 The on state of charge pump circuit

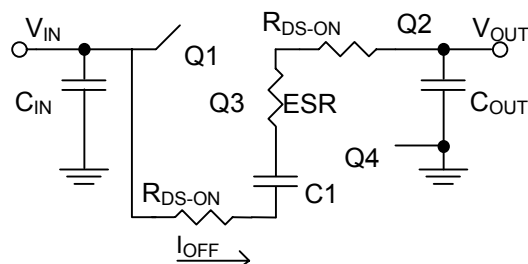

Fig. 12 The off state of charge pump circuit

External Capacitor Selection

Three external capacitors, C_{IN} , C_{OUT} and C_{FLY} , determine AIC1848 performances, in the aspects of output ripple voltage, charge pump strength and transient. Optimum performance can be obtained by the use of ceramic capacitors with low ESR. Due to high ESR, capacitors of tantalum and aluminum are not recommended for charge pump application.

To reduce noise and ripple, a low ESR ceramic capacitor, is recommended for C_{IN} and C_{OUT} . The value of C_{OUT} determines the amount of output ripple voltage. An output capacitor with larger value results in smaller ripple.

C_{FLY} is critical for the strength of charge pump. The larger C_{FLY} is, the larger output current and smaller ripple voltage obtain. However, large C_{IN} and C_{OUT} are expected when a large C_{FLY} applies. The ratio of C_{IN} (as well as C_{OUT}) to C_{FLY} should be approximately 10:1.

The value of capacitors, which is used under operation condition, determines the performance of a charge pump converter. And two factors, as follows, affect the capacitance of capacitor.

1. **Material:** Ceramic capacitors of different materials, such as X7R, X5R, Z5U and Y5V, have different tolerance in temperature and different capacitance loss. For example, a X7R or X5R type of capacitor can retain most of the capacitance at temperature from -40°C to 85°C , but a Z5U or Y5V type will lose most of the capacitance at that temperature range.
2. **Package Size:** A ceramic capacitor with large volume (0805), gets a lower ESR than a small one (0603). Therefore, large devices

can improve more transient response than small ones.

Table 1 lists the recommended components for AIC1848 application.

Table.1 Bill of Material

| Designator | Part Type | Description | Vendor | Phone |
|------------------|-----------|---------------|-------------|-----------------|
| C _{IN} | 1 μ | JMK107BJ105KA | TAIYO YUDEN | (02) 27972155~9 |
| C _{FLY} | 0.1 μ | EMK107BJ104KA | TAIYO YUDEN | (02) 27972155~9 |
| C _{OUT} | 1 μ | JMK107BJ105KA | TAIYO YUDEN | (02) 27972155~9 |

Layout Considerations

Due to the switching frequency and high transient current of AIC1848, careful consideration of PCB layout is necessary. To achieve the best performance of AIC1848, minimize the distance between every two components and also minimize every connection length with a maximum trace width. Make sure each device connects to immediate ground plane. Fig. 13 to Fig. 15 show the recommended layout.

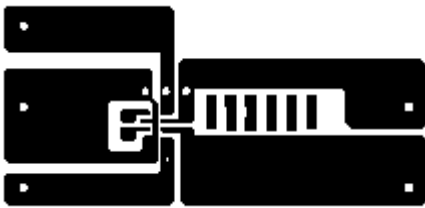

Fig. 13 Top layer



Fig. 14 Bottom layer

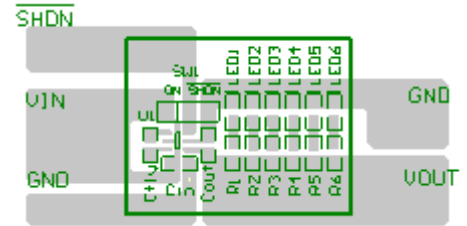

Fig. 15 Topover layer

■ APPLICATION EXAMPLES

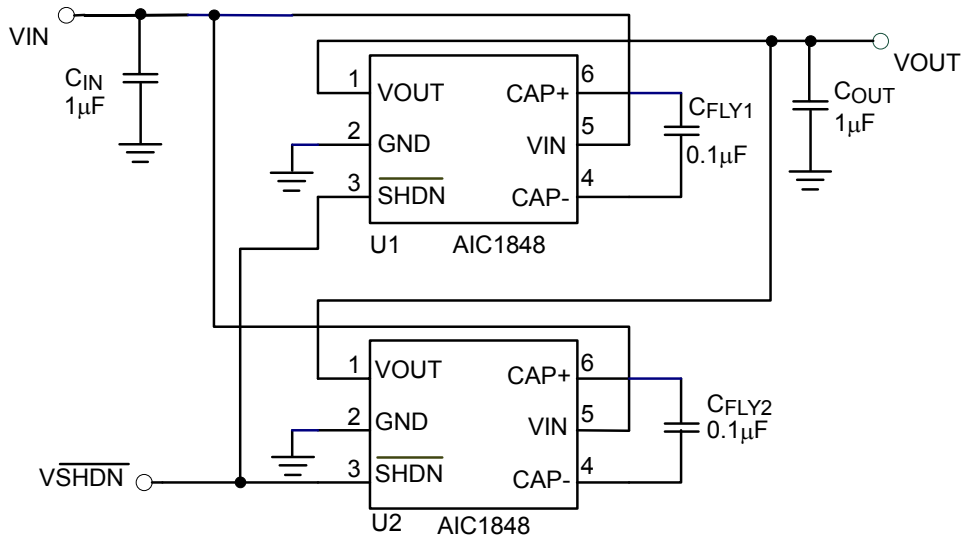

Fig. 16 Parallel Two AIC1848 to Obtain the Regulated 5V Output with large output current.

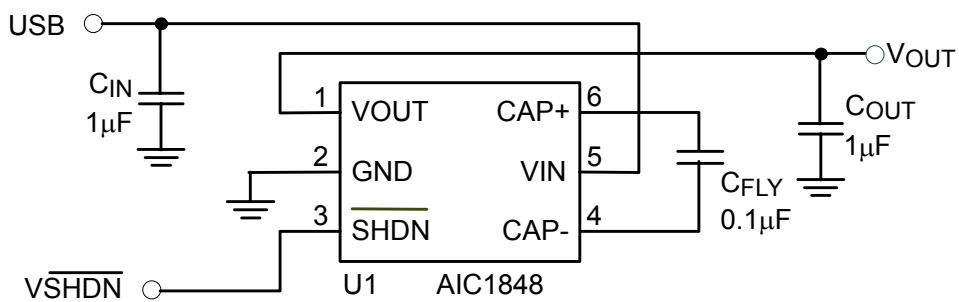
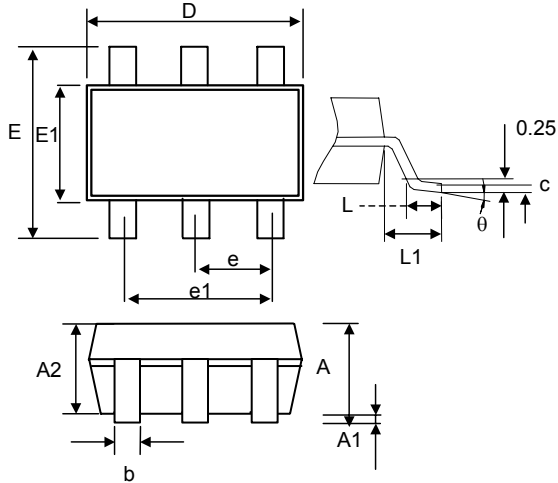

Fig. 17 Regulated 5V from USB

PHYSICAL DIMENSIONS (unit: mm)
SOT-23-6

| SYMBOL | MIN | MAX |
|----------|----------|------|
| A | 0.95 | 1.45 |
| A1 | 0.05 | 0.15 |
| A2 | 0.90 | 1.30 |
| b | 0.30 | 0.50 |
| c | 0.08 | 0.22 |
| D | 2.80 | 3.00 |
| E | 2.60 | 3.00 |
| E1 | 1.50 | 1.70 |
| e | 0.95 BSC | |
| e1 | 1.90 BSC | |
| L | 0.30 | 0.60 |
| L1 | 0.60 REF | |
| θ | 0° | 8° |

Note:

Information provided by AIC is believed to be accurate and reliable. However, we cannot assume responsibility for use of any circuitry other than circuitry entirely embodied in an AIC product; nor for any infringement of patents or other rights of third parties that may result from its use. We reserve the right to change the circuitry and specifications without notice.

Life Support Policy: AIC does not authorize any AIC product for use in life support devices and/or systems. Life support devices or systems are devices or systems which, (i) are intended for surgical implant into the body or (ii) support or sustain life, and whose failure to perform, when properly used in accordance with instructions for use provided in the labeling, can be reasonably expected to result in a significant injury to the user.