



■ Features

- Synchronous Controller in 8-Pin Package
- Operating with single 5V or 12V supply voltage
- Internal 200KHz Oscillator (400KHz for AP2014A)
- Soft-Start Function
- Fixed Frequency Voltage Mode
- 500mA Peak Output Drive Capability
- Protects the output when control FET is shorted
- SOP-8L/PDIP-8L **Pb-Free** package

■ Applications

- Graphic Card
- Hard Disk Drive
- DDR memory source sink Vtt application
- Low cost on-board DC to DC such as 5V to 3.3V, 2.5V or 1.8V

■ General Description

The AP2014 controller IC is designed to provide a low cost synchronous Buck regulator for on-board DC to DC converter applications. With the migration of today's ASIC products requiring low supply voltages such as 1.8V and lower, together with currents in excess of 3A, traditional linear regulators are simply too lossy to be used when input supply is 5V or even in some cases with 3.3V input supply. The AP2014 together with dual N-channel MOSFETs such as AF9410, provide a low cost solution for such applications. This device features an internal 200KHz oscillator (400KHz for "A" version), under-voltage lockout for both Vcc and Vc supplies, an external programmable soft-start function as well as output under-voltage detection that latches off the device when an output short is detected.

■ Pin Assignments

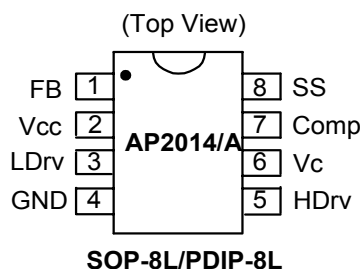

■ Pin Descriptions

Pin Name	Pin No.	Description
FB	1	This pin is connected directly to the output of the switching regulator via resistor divider to provide feedback to the Error amplifier.
Vcc	2	This pin provides biasing for the internal blocks of the IC as well as power for the low side driver. A minimum of 1F, high frequency capacitor must be connected from this pin to ground to provide peak drive current capability.
LDrv	3	Output driver for the synchronous power MOSFET.
GND	4	This pin serves as the ground pin and must be connected directly to the ground plane. A high frequency capacitor (0.1 to 1F) must be connected from V5 and V12 pins to this pin for noise free operation.
HDrv	5	Output driver for the high side power MOSFET.
Vc	6	This pin is connected to a voltage that must be at least 4V higher than the bus voltage of the switcher (assuming 5V threshold MOSFET) and powers the high side output driver. A minimum of 1F, high frequency capacitor must be connected from this pin to ground to provide peak drive current capability.
Comp	7	Compensation pin of the error amplifier. An external resistor and capacitor network is typically connected from this pin to ground to provide loop compensation.
SS	8	This pin provides soft-start for the switching regulator. An internal current source charges an external capacitor that is connected from this pin to ground which ramps up the output of the switching regulator, preventing it from overshooting as well as limiting the input current. The converter can be shutdown by pulling this pin below 0.5V.



■ **Ordering Information**

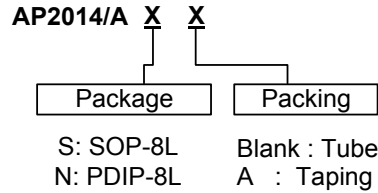

■ **Block Diagram**

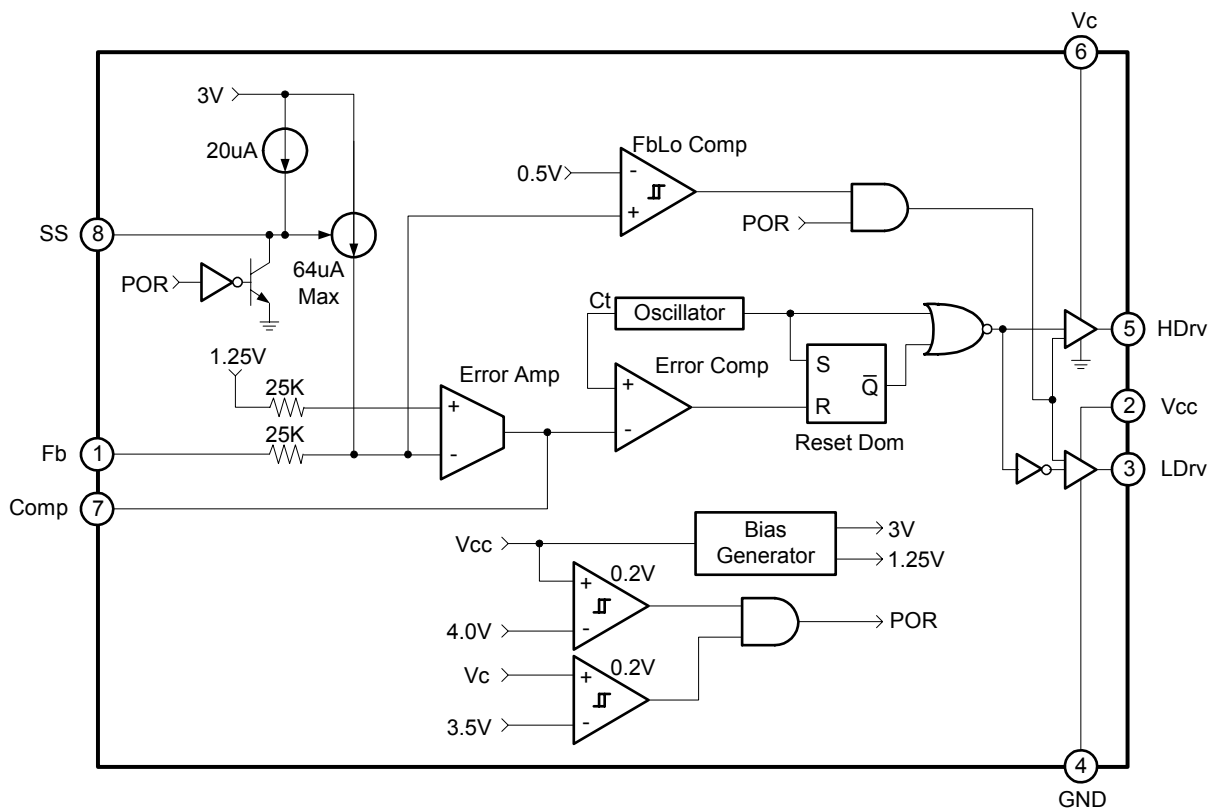

■ **Absolute Maximum Ratings**

Symbol	Parameter	Range.	Unit
V _{CC}	V _{CC} Supply Voltage	20	V
V _C	V _C Supply Voltage (not rated for inductive load)	30	V
T _{ST}	Storage Temperature Range	-65 to 150	°C
T _J	Operating Junction Temperature Range	0 to 125	°C



■ Electrical Characteristics

Unless otherwise specified, these specifications apply over $V_{CC}=5V$, $V_C=12V$ and $T_A=0$ to $70^\circ C$. Typical values refer to $T_A=25^\circ C$. Low duty cycle pulse testing is used which keeps junction and case temperatures equal to the ambient temperature.

Symbol	Parameter	Conditions	Min.	Typ.	Max.	Unit
Reference Voltage						
V_{FB}	FB Voltage	AP2014	1.225	1.25	1.275	V
		AP2014A	0.784	0.8	0.816	
L_{REG}	FB Voltage Line Regulation	$5 < V_{CC} < 12$	-	0.2	0.35	%
UVLO						
$UVLO V_{CC}$	UVLO Threshold - V_{CC}	Supply Ramping Up	4.0	4.2	4.4	V
	UVLO Hysteresis - V_{CC}		-	0.25	-	V
$UVLO V_C$	UVLO Threshold - V_C	Supply Ramping Up	3.1	3.3	3.5	V
	UVLO Hysteresis - V_C		-	0.2	-	V
$UVLO FB$	UVLO Threshold - FB	FB Ramping Down (AP2014)	0.4	0.6	0.8	V
		FB Ramping Down (AP2014A)	0.3	0.4	0.5	V
	UVLO Hysteresis - FB	-	0.1	-	V	
Supply Current						
Operation I_{CC}	V_{CC} Operation Supply Current	Freq=200KHz, $C_L=1500pF$	-	7	10	mA
Operation I_C	V_C Operation Supply Current	Freq=200KHz, $C_L=1500pF$	-	7	10	mA
I_{CCQ}	V_{CC} Static Supply Current	SS=0V	-	3.3	6	mA
I_{CQ}	V_C Static Supply Current	SS=0V	-	1	4.5	mA
Soft-Start Section						
SS_{IB}	Charge Current	SS=0V	10	20	30	μA
Error Amp						
I_{FB1}	FB Voltage Input Bias Current	SS=3V, FB=1V	-	-0.1	-	μA
I_{FB2}	FB Voltage Input Bias Current	SS=0V, FB=1V	-	-64	-	μA
gm	Transconductance		450	600	750	μmho
Oscillator						
Freq	Frequency	AP2014	170	200	230	KHz
		AP2014A	340	400	460	KHz
V_{RAMP}	Ramp-Amplitude Voltage		1.225	1.25	1.275	V
Output Drivers						
T_r	Rise Time	$C_L = 1500pF$	-	50	100	ns
T_f	Fall Time	$C_L = 1500pF$	-	50	100	ns
T_{DB}	Dead Band Time		50	150	250	ns
T_{ON}	Max Duty Cycle	FB=1V, Freq=200KHz	85	90	95	%
T_{OFF}	Min Duty Cycle	FB=1.5V	0	0	-	%

■ **Typical Application Circuit**

(1)

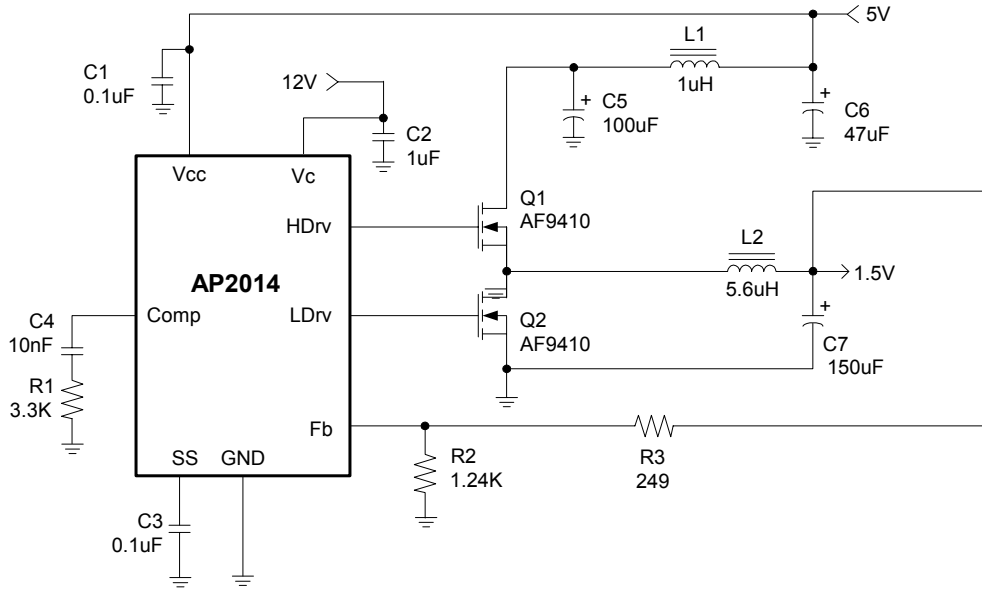

(2)

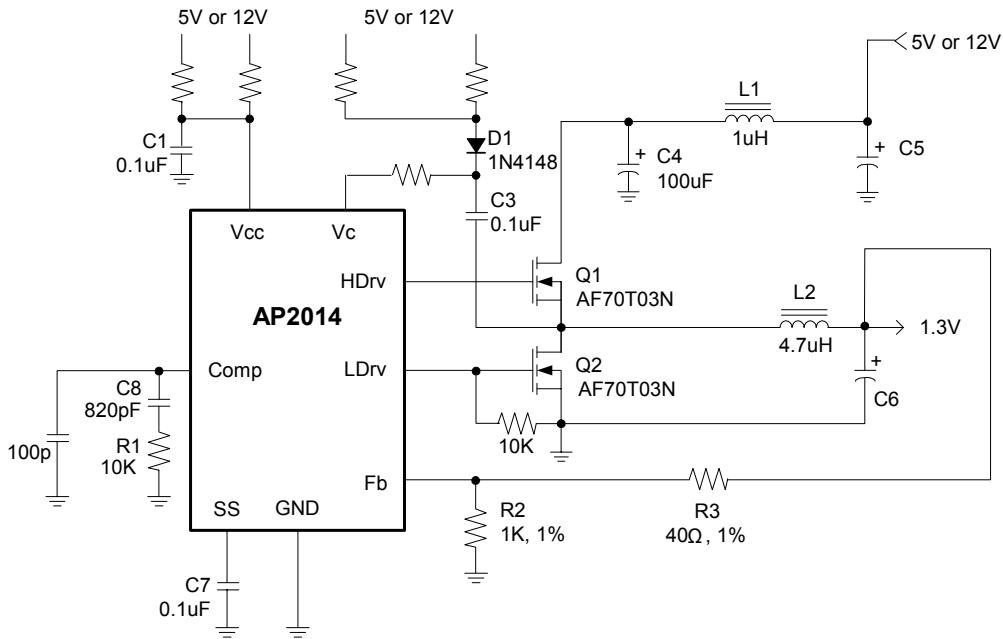

Single Supply 5V Input

■ **Typical Application Circuit (Continued)**

(3) **Dual Supply, 5V Bus and 12V Bias Input**

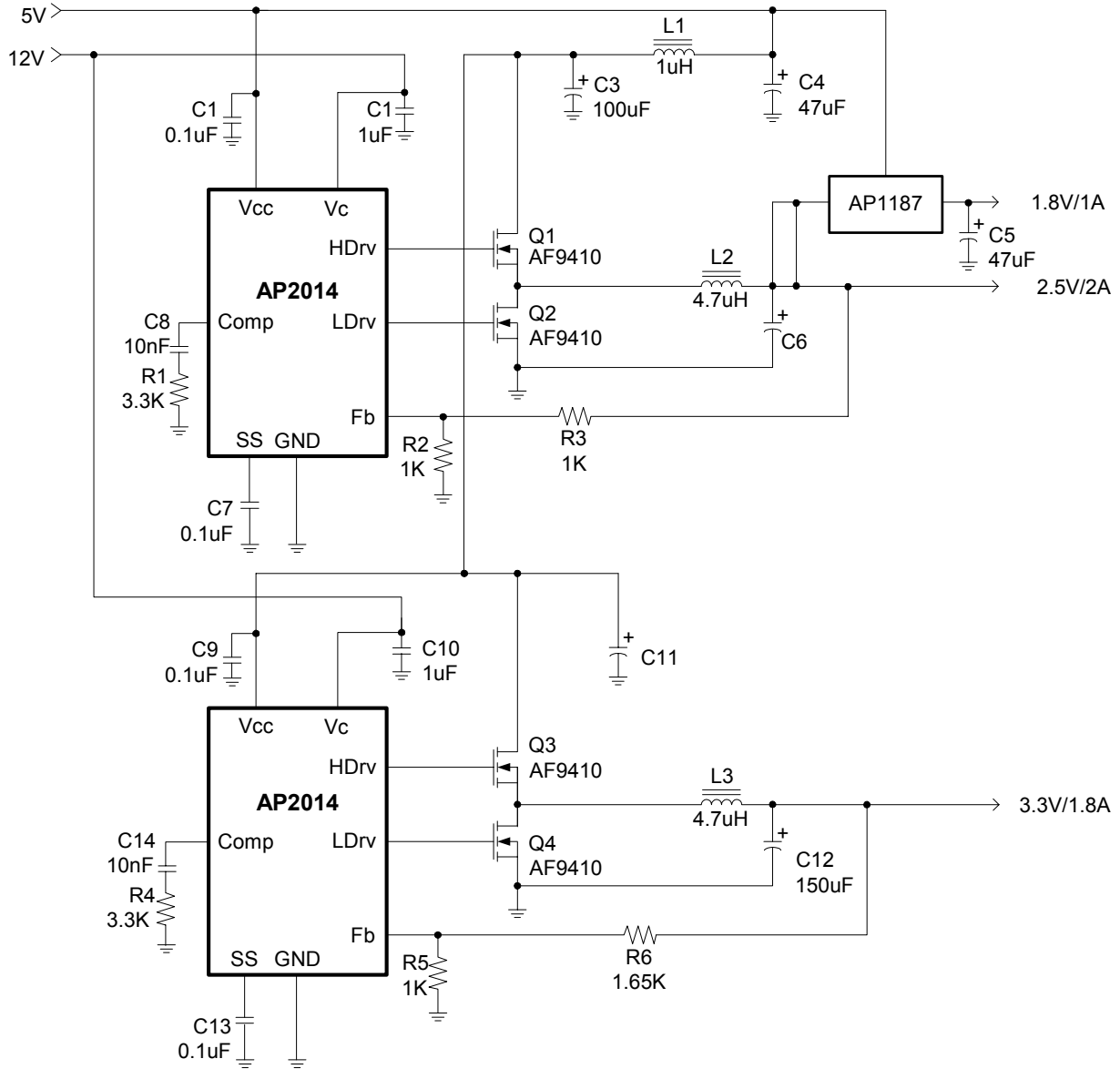

Dual Supply, 5V Bus and 12V Bias Input

■ **Typical Performance Characteristics**

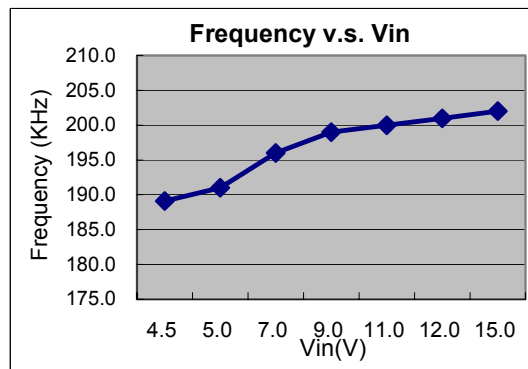
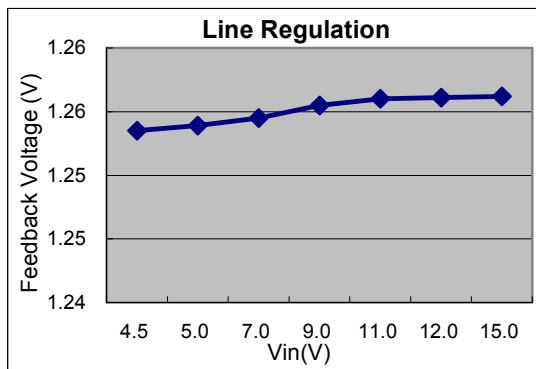
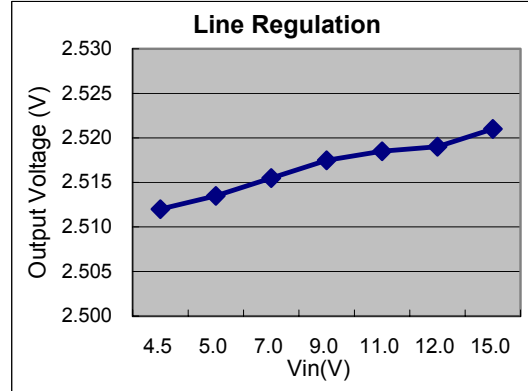
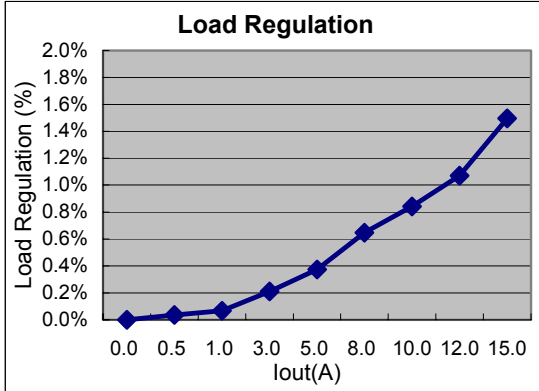

■ Typical Performance Characteristics (Continued)

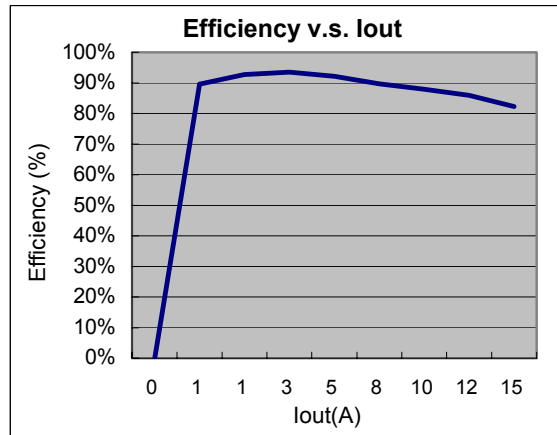
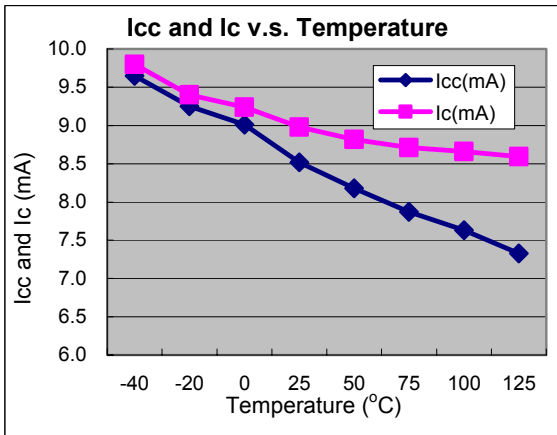
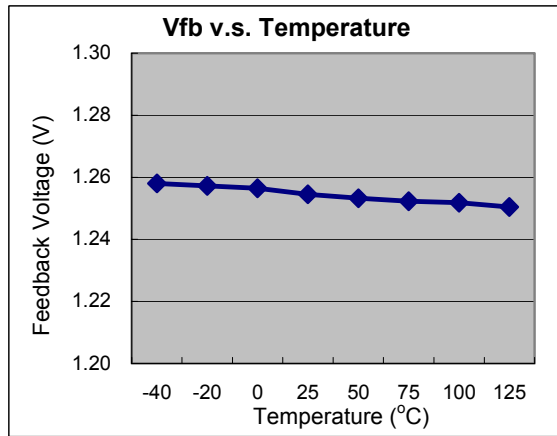
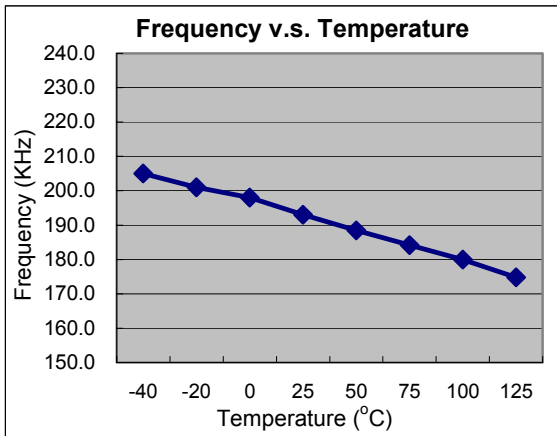
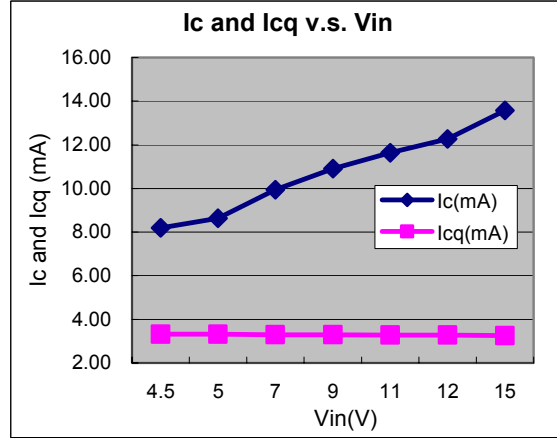
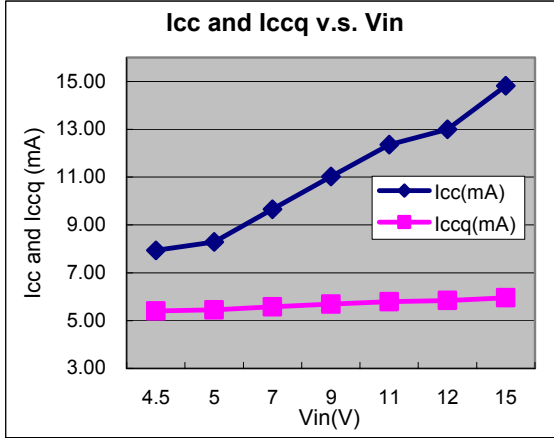

■ Typical Performance Characteristics (Continued)

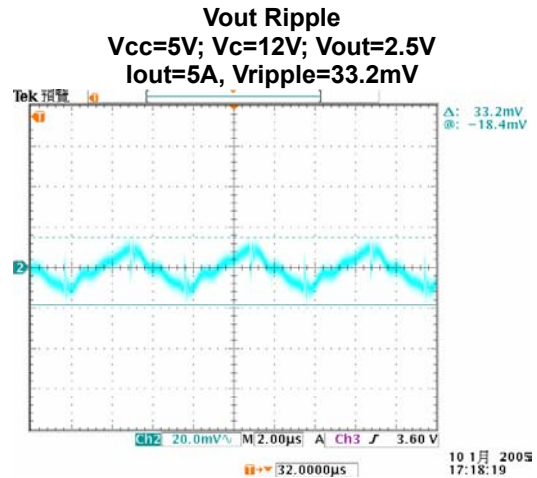
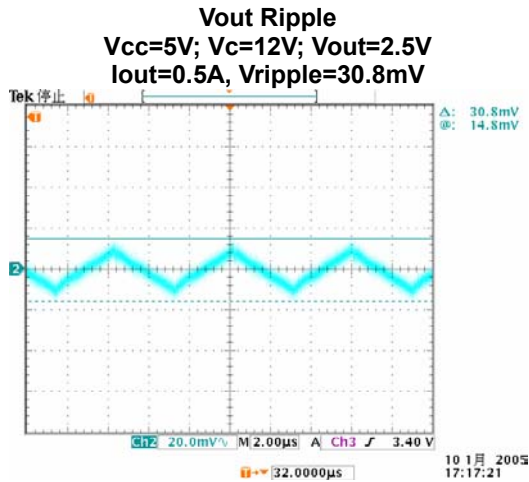

Dead time v.s. I_{out}

$V_{cc}=5V$, $V_c=12V$, $V_{out}=2.5V$, $I_{out}=0.5A$, $Temp=28^{\circ}C$

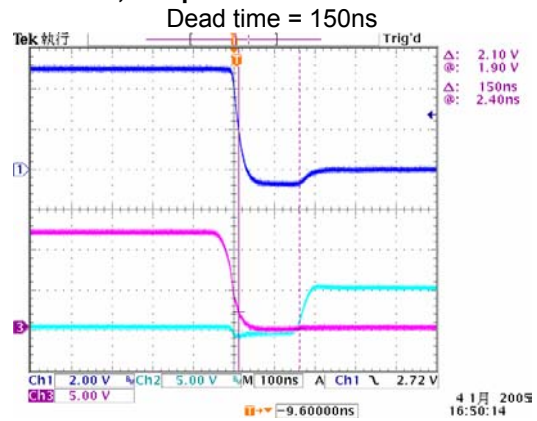
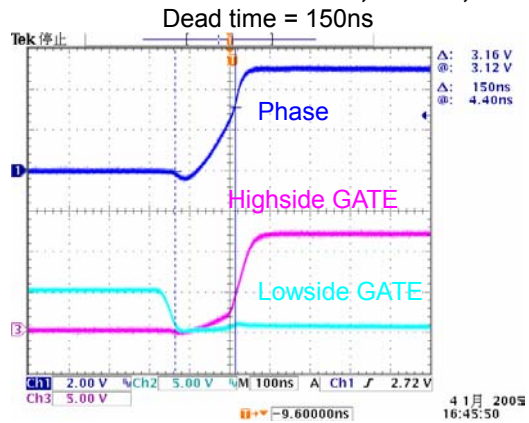

Dead time v.s. I_{out}

$V_{cc}=5V$, $V_c=12V$, $V_{out}=2.5V$, $I_{out}=5A$, $Temp=28^{\circ}C$

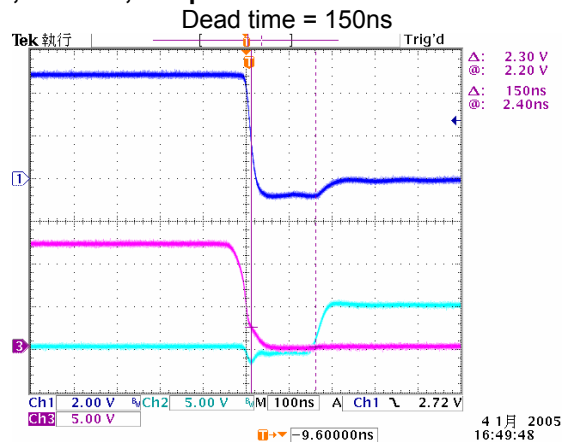
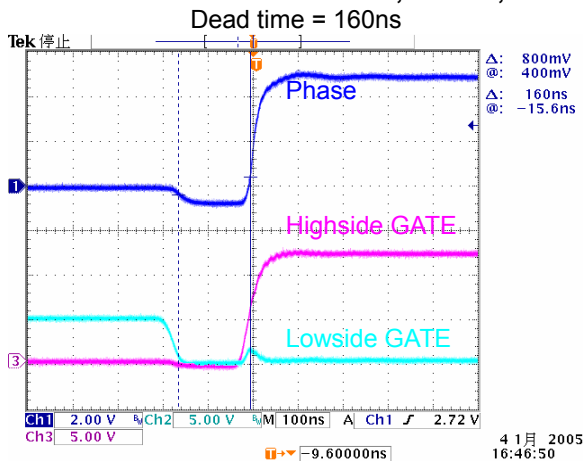



■ Function Descriptions

Introduction

The AP2014 is a fixed frequency, voltage mode synchronous controller and consists of a precision reference voltage, an error amplifier, an internal oscillator, a PWM comparator, 0.5A peak gate driver, soft-start and shutdown circuits (see Block Diagram).

The output voltage of the synchronous converter is set and controlled by the output of the error amplifier; this is the amplified error signal from the sensed output voltage and the reference voltage.

This voltage is compared to a fixed frequency linear sawtooth ramp and generates fixed frequency pulses of variable duty-cycle, which drives the two N-channel external MOSFETs. The timing of the IC is provided through an internal oscillator circuit which uses on-chip capacitor to set the oscillation frequency to 200 KHz (400 KHz for "A" version).

Soft-Start

The AP2014 has a programmable soft-start to control the output voltage rise and limit the current surge at the start-up. To ensure correct start-up, the soft-start sequence initiates when the V_C and V_{CC} rise above their threshold (3.3V and 4.2V respectively) and generates the Power On Reset (POR) signal. Soft-start function operates by

sourcing an internal current to charge an external capacitor to about 3V. Initially, the soft-start function clamps the E/A's output of the PWM converter. As the charging voltage of the external capacitor ramps up, the PWM signals increase from zero to the point the feedback loop takes control.

Short-Circuit Protection

The outputs are protected against the short circuit. The AP2014 protects the circuit for shorted output by sensing the output voltage (through the external resistor divider). The AP2014 shuts down the PWM signals, when the output voltage drops below 0.6V (0.4V for AP2014A).

The AP2014 also protects the output from over-voltaging when the control FET is shorted. This is done by turning on the sync FET with the maximum duty cycle.

Under-Voltage Lockout

The under-voltage lockout circuit assures that the MOSFET driver outputs remain in the off state whenever the supply voltage drops below set parameters. Lockout occurs if V_C and V_{CC} fall below 3.3V and 4.2V respectively. Normal operation resumes once V_C and V_{CC} rise above the set values.

■ Marking Information

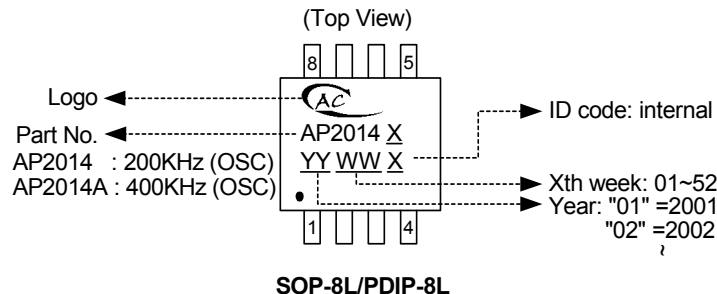

■ Package Information

Package Type: SOP-8L

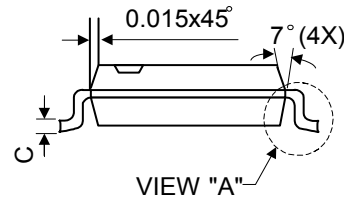
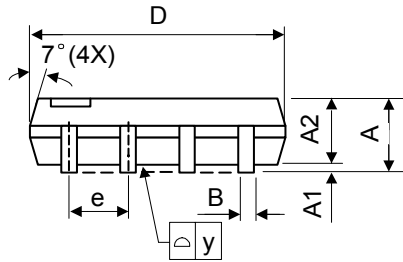
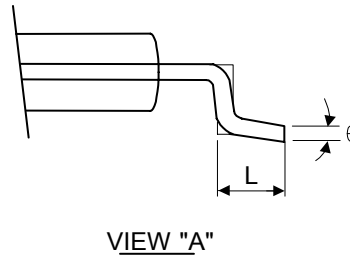
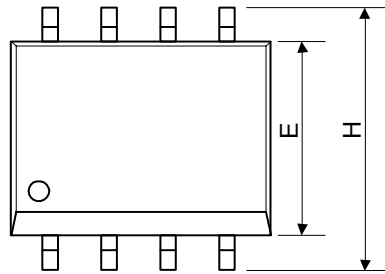

Symbol	Dimensions In Millimeters			Dimensions In Inches		
	Min.	Nom.	Max.	Min.	Nom.	Max.
A	1.40	1.60	1.75	0.055	0.063	0.069
A1	0.10	-	0.25	0.040	-	0.100
A2	1.30	1.45	1.50	0.051	0.057	0.059
B	0.33	0.41	0.51	0.013	0.016	0.020
C	0.19	0.20	0.25	0.0075	0.008	0.010
D	4.80	5.05	5.30	0.189	0.199	0.209
E	3.70	3.90	4.10	0.146	0.154	0.161
e	-	1.27	-	-	0.050	-
H	5.79	5.99	6.20	0.228	0.236	0.244
L	0.38	0.71	1.27	0.015	0.028	0.050
y	-	-	0.10	-	-	0.004
θ	0°	-	8°	0°	-	8°



■ Package Information (Continued)

Package Type: PDIP-8L

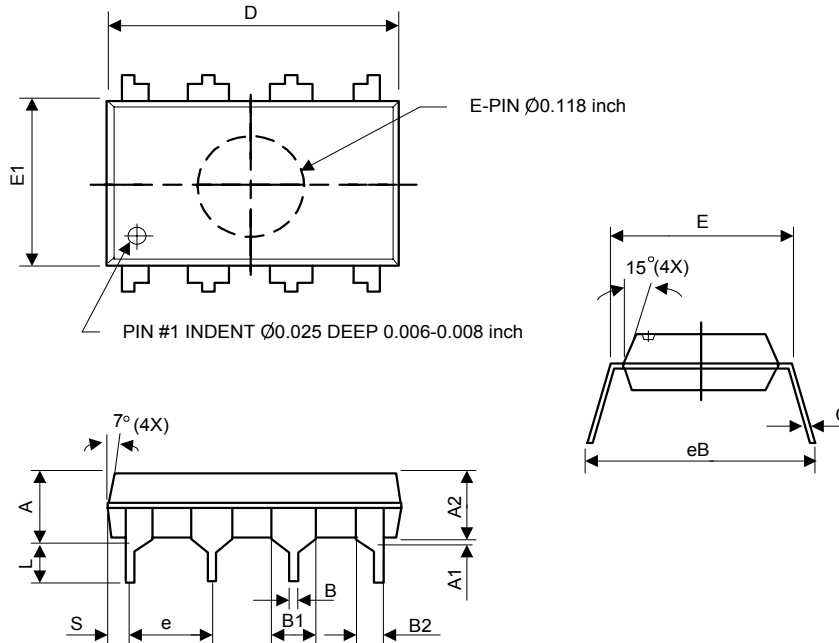

Symbol	Dimensions in millimeters			Dimensions in inches		
	Min.	Nom.	Max.	Min.	Nom.	Max.
A	-	-	5.33	-	-	0.210
A1	0.38	-	-	0.015	-	-
A2	3.1	3.30	3.5	0.122	0.130	0.138
B	0.36	0.46	0.56	0.014	0.018	0.022
B1	1.4	1.52	1.65	0.055	0.060	0.065
B2	0.81	0.99	1.14	0.032	0.039	0.045
C	0.20	0.25	0.36	0.008	0.010	0.014
D	9.02	9.27	9.53	0.355	0.365	0.375
E	7.62	7.94	8.26	0.300	0.313	0.325
E1	6.15	6.35	6.55	0.242	0.250	0.258
e	-	2.54	-	-	0.100	-
L	2.92	3.3	3.81	0.115	0.130	0.150
eB	8.38	8.89	9.40	0.330	0.350	0.370
S	0.71	0.84	0.97	0.028	0.033	0.038