

Nexperia™ PNX83xx intelligent bolt-on solution

The DTT reference design based on Nexperia reduces design effort and risk for manufacturers by providing a low cost, short time-to-market route for the introduction of new iDTV bolt-on modules and re-use of the developments for Set-Top Box (STB) receivers.



Applications

- Cost effective iDTV bolt-on modules
- Set-top boxes for digital terrestrial television
- Integration possible into DVD+RW recorders, VCR and PC TV solutions

Features

- Complete ready to build, proven reference design for low cost FTA DTV reception
- Only one 16-Mbyte SDRAM and one 4-Mbyte NOR flash memory required
- Digital audio output (S/PDIF) for home theater systems
- Interfaces for back-channel modem
- Support for conditional access smart card and PCMCIA software upgrade readers
- Diagnostic software, terrestrial, RS232 and flashcard download facilities
- IBOLink interface offers plug & play migration to other Philips' Nexperia family bolt-on reference solutions
- Controlled via I²C bus interface using Philips' IBOLink command protocol

DTT reference design for low cost TV DVB-T receivers

Semiconductors

The DTT reference design allows DVB (Digital Video Broadcast) capabilities to be added to existing low-end and mid-end analog TV set designs. Promoting the availability of the low cost iDTV sets and STBs needed for the widespread roll-out of digital terrestrial TV services, it enables the further penetration of digital services into the connected home.

Based on Philips' PNX83xx Nexperia™ family of DTV semiconductor solutions, this basic reference system greatly reduces the need for application software development. Supplied in a form that can be integrated easily into a conventional analog TV chassis, it can also be used as a system solution to make a STB receiver, further reducing the design effort for manufacturers active in both Digital TV as well as STB applications.

The reference design is based around Philips' new PNX83xx Home Entertainment Engine and TDA10046 channel decoder. Manufactured in Philips' latest 0.12 μm high-volume CMOS process, the PNX83xx handles all the media processing of the decoded digital signals from the TDA10046 and also provides interfaces for the back-channel modem plus conditional access smart card and PCMCIA software upgrade readers. Overall system costs are kept low by reducing the system memory requirement for standard DVB reception to a single 16-Mbyte SDRAM and a 4-Mbyte NOR Flash memory. The entire system is controlled by the TV set's microcontroller via the I²C-bus interface using Philips' IBOLink command protocol.

The reference design can be supplied with a choice of proven MHEG (Multimedia and Hypermedia information coding Expert Group) software stacks, making it suitable for digital TVs and STBs destined for countries such as the United Kingdom, where this standard has already been adopted for enhanced digital TV.

PHILIPS

Nexperia™ PNX83xx intelligent bolt-on solution

DTT reference design for low cost TV DVB-T receivers



In addition to providing a simple system solution with a low bill of materials, the reference design also minimizes the customer's risk in terms of software licensing fees. By shifting the main license cost from an up-front fee to a per-use fee, customers only pay in relation to the volume of digital TVs or set-top-boxes they produce.

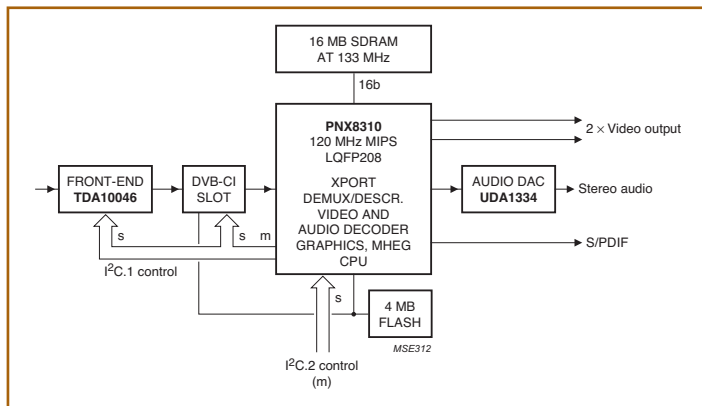

PNX83xx Intelligent bolt-on solution



Example middleware application

Philips Semiconductors

Philips Semiconductors is a worldwide company with over 100 sales offices in more than 50 countries. For a complete up-to-date list of our sales offices please e-mail sales.addresses@www.semiconductors.philips.com. A complete list will be sent to you automatically. You can also visit our website <http://www.semiconductors.philips.com/sales>.

© Koninklijke Philips Electronics N.V. 2003

All rights reserved. Reproduction in whole or in part is prohibited without the prior written consent of the copyright owner. The information presented in this document does not form part of any quotation or contract, is believed to be accurate and reliable and may be changed without notice. No liability will be accepted by the publisher for any consequence of its use. Publication thereof does not convey nor imply any license under patent- or other industrial or intellectual property rights.



Date of release: August 2003
Document order number: 9397 750 11773

Published in The Netherlands