

# DATA SHEET

## **IP4220CZ6**

Dual USB 2.0 Integrated ESD  
protection to IEC 61000-4-2 level 4

Preliminary Specification

2004 September 17

## Dual USB 2.0 Integrated ESD Protection

IP4220CZ6

### FEATURES

- ESD IEC 61000-4-2 level 4,  $\pm 8$ kV contact discharge compliant protection
- Four ultra-low input capacitance (1 pF typ.) ESD rail-to-rail protection diodes
- Low voltage clamping due to integrated Zener diode
- Small 6 lead SO6 (SOT457) package



### APPLICATIONS

General-purpose downstream ESD protection high frequency analog signals and high-speed serial data transmission for ports inside:

- Cellular and PCS mobile handsets
- PC-/Notebook USB2.0/IEEE1394 ports
- DVI interfaces
- Cordless telephones
- Wireless data (WAN/LAN) systems
- PDAs

### DESCRIPTION

The IP4220CZ6 is designed to protect I/Os being sensitive concerning capacitive load, such as USB 2.0, Ethernet, DVI etc. from destruction by Electro Static Discharges (ESD).

Therefore, the IP4220CZ6 incorporates four pairs of ultra-low capacity rail-to-rail diodes plus an additional Zener diode to provide protection to downstream signal and supply components from Electrostatic Discharge (ESD) voltages as high as  $\pm 8$  kV contact discharge.

Due to the rail-to-rail diodes being connected to the Zener diode, the protection is working independent from the availability of a supply voltage.

The IP4220CZ6 is fabricated using thin film-on-silicon technology and integrates 4 ultra-low capacity rail-to-rail ESD protection diodes in a miniature 6-lead SOT457 package.

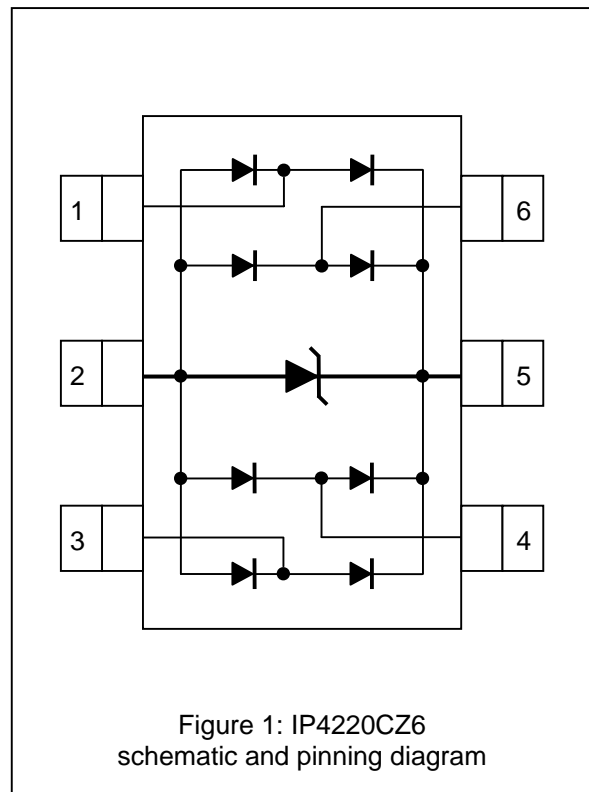

## Dual USB 2.0 Integrated ESD Protection

IP4220CZ6

### ABSOLUTE MAXIMUM RATINGS

SYMBOL	PARAMETER	TEST CONDITIONS	MIN	MAX	UNIT
$V_{I/O}$	DC input voltage range		0	+5.5	V
ESD	Electrostatic Discharge, all pins	IEC 61000-4-2, Level 4, Contact	-8	+8	kV
$T_{stg}$	Device storage temperature range		-55	+125	°C

### RECOMMENDED OPERATING CONDITIONS

	MIN	MAX	UNIT
Operating temperature range	-40	+85	°C

### ELECTRICAL CHARACTERISTICS

$T_c = 25^\circ\text{C}$  unless otherwise specified

SYMBOL	PARAMETER	TEST CONDITIONS	MIN	TYP	MAX	UNIT
$C_{I/O}$	Pin capacitance to ground, Pins 1, 3, 4, 6	$V_{dc} = 0\text{ V}$ ; $f = 1\text{ MHz}$ Pin 5 = +3.0 V	-	1.0	-	pF
$I_{lkg}$	Diode reverse leakage current, Pins 1, 3, 4, 6 to ground	$V = +3.0\text{ V}$	-	-	100	nA
$C_{Zener}$	Zener diode capacitance to ground, Pin 5 to 2	$V_{dc} = 0\text{ V}$ ; $f = 1\text{ MHz}$ Pin 5 = +3.0 V	-	40	-	pF
$V_{BR\ I/O}$	Zener diode breakdown voltage, Pin 5 to 2	$I = 1\text{ mA}$	6	-	9	V
$V_F$	Forward voltage		-	0.7	-	V

Dual USB 2.0  
Integrated ESD Protection

IP4220CZ6

Application Information

Universal Serial Bus 2.0 protection

The IP4220CZ6 is optimized to protect e.g. two USB 2.0 ports of Electro-Static-Discharge (ESD). Each device is capable of protection both USB data lines and the  $V_{BUS}$  supply. A typical application is shown in the schematic below.

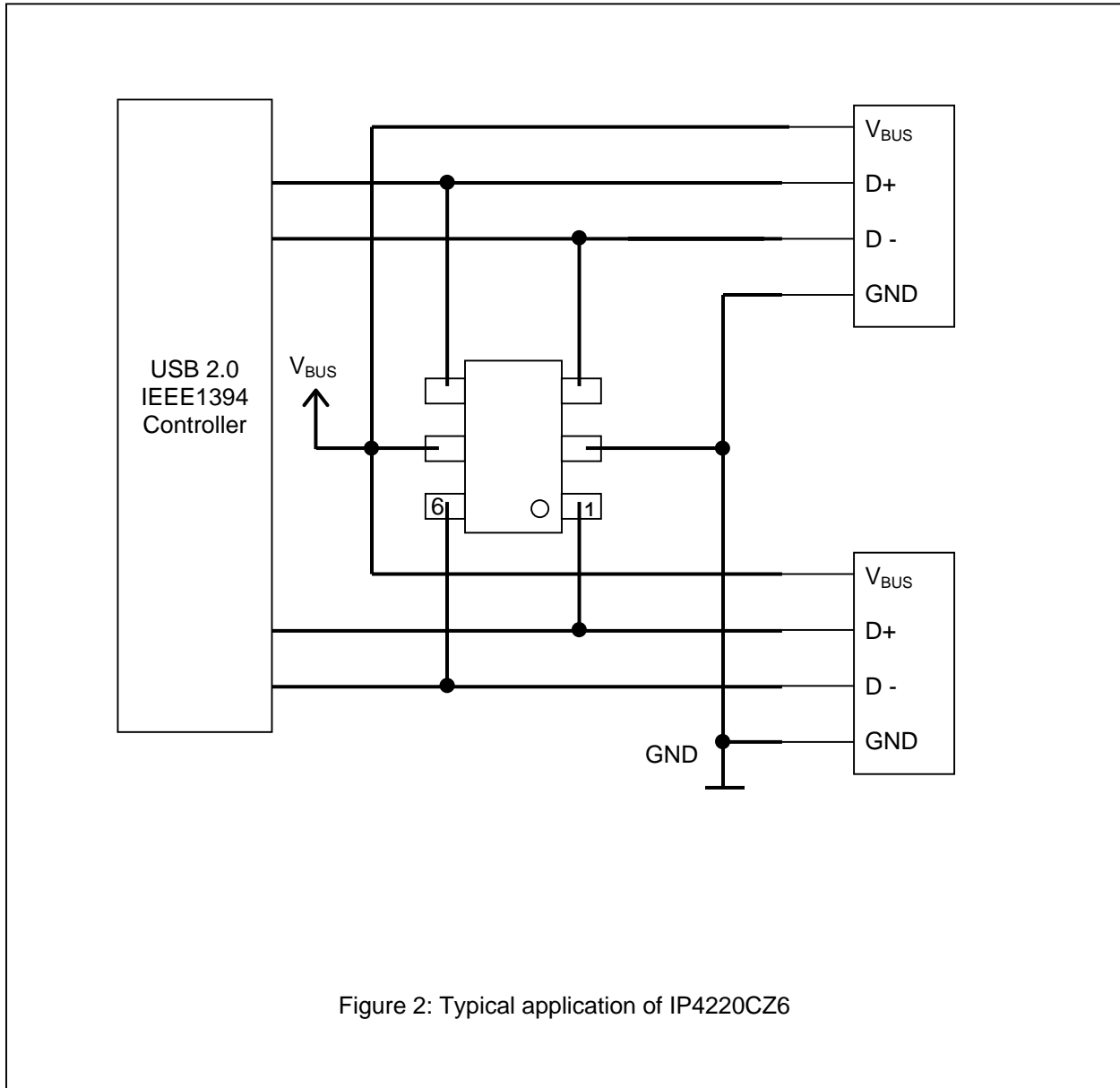

Figure 2: Typical application of IP4220CZ6

Dual USB 2.0  
Integrated ESD Protection

IP4220CZ6

PACKAGE OUTLINE

Plastic small outline package; 6 leads; body width 1.5 mm

SOT457

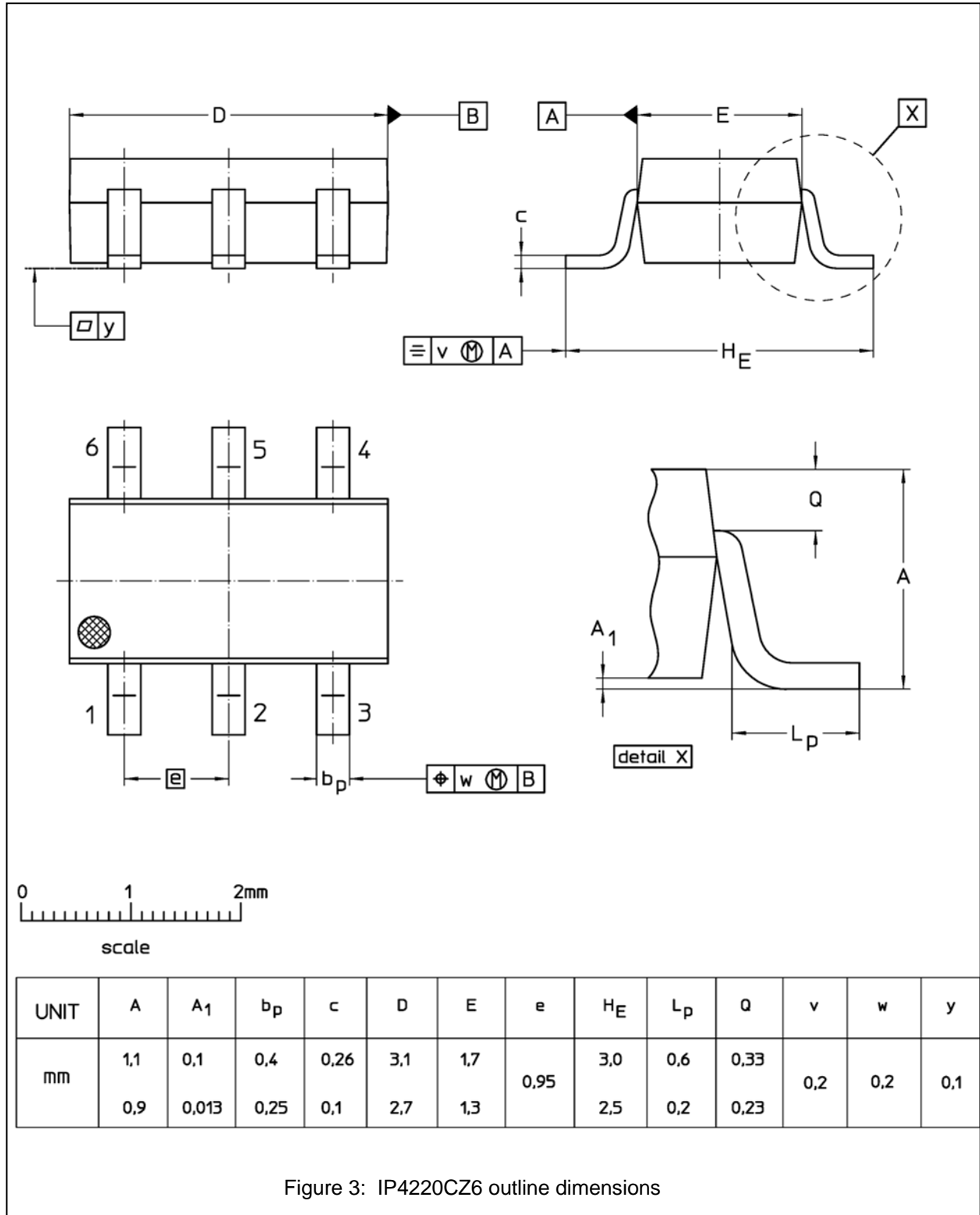

# Dual USB 2.0

## Integrated ESD Protection

IP4220CZ6

### DEFINITIONS

Data Sheet Identification	Product Status	Definition
<i>Objective Specification</i>	Formative or in Design	This data sheet contains the target or goal specifications for product development. Specifications may change in any manner without notice.
<i>Preliminary Specification</i>	Preproduction Product	This data sheet contains preliminary data, and supplementary data will be published at a later date. Philips Semiconductors reserves the right to make changes at any time without notice in order to improve the design and supply the best possible product.
<i>Product Specification</i>	Full Production	This data sheet contains Final Specifications. Philips Semiconductors reserves the right to make changes at any time without notice in order to improve the design and supply the best possible product.

Philips Semiconductors and Philips Electronics North America Corporation reserve the right to make changes, without notice in the products, including circuits, standard cells, and/or software, described or contained herein in order to improve design and/or performance. Philips Semiconductors assumes no responsibility or liability for the use of any of these products, conveys no license or title under any patent, copyright, or mask work right to these products, and makes no representations or warranties that these products are free from patent, copyright, or mask work infringement, unless otherwise specified. Applications that are described herein for any of these products are for illustrative purposes only. Philips Semiconductors makes no representation or warranty that such applications will be suitable for the specified use without further testing or modification.

### LIFE SUPPORT APPLICATIONS

Philips Semiconductors and Philips Electronics North America Corporation Products are not designed for use in life support appliances, devices, or systems where malfunction of a Philips Semiconductors and Philips Electronics North America Corporation Product can reasonably be expected to result in a personal injury. Philips Semiconductors and Philips Electronics North America Corporation customers using or selling Philips Semiconductors and Philips Electronics North America Corporation Products for use in such applications do so at their own risk and agree to fully indemnify Philips Semiconductors and Philips Electronics North America Corporation for any damages resulting from such improper use or sale.



# PHILIPS