



LV24000/02Development

Specifications

Ultra-compact FM tuner IC for mobile set

Overview

The LV24000/02 is FM tuner IC's that requires absolutely no external components.

They incorporates not only the FM tuner functions but master volume control, tone control, buzzer, source selector, Head phone amp and other functions as well in a compact VQLP package with dimensions of only 5 x 5 x 0.8mm.

These IC's are simply ideal for incorporating FM tuner functions into mobile phones and other small mobile set where space is always at a premium.

Functions

LV24000

FM FE / FM IF / MPX Stereo Decoder / Tuning / Volume control / Tone control / Buzzer

LV24002

LV24000 function + Source selector + Head phone amp

Features

- No external components
- No alignments necessary
- Fully integrated low IF selectivity and demodulation
- Built in adjacent channel interference total reduction (no 114kHz, no 190kHz)
- Due to new tuning concept, the tuning is independent of the channel spacing
- Very high sensitivity due to integrated low noise RF input amplifier
- Very low power Standby mode. No power switch circuitry required
- MPX output for RDS application
- 3-wire bus interface (Data, Clock, NR-W)
- Digital AFC - Tuner locks to frequency after tuning sequence
- 8 level programmable Soft Mute
- 8 level programmable Stereo Blend
- In combination with the host, fast, low power operation of preset mode, manual search, automatic search and automatic preset store are possible
- Covers all Japanese, European and US bands

Package dimension

LV24000/02PL VQLP40 (5 x 5 x 0.8 mm)

IC Package Dimension

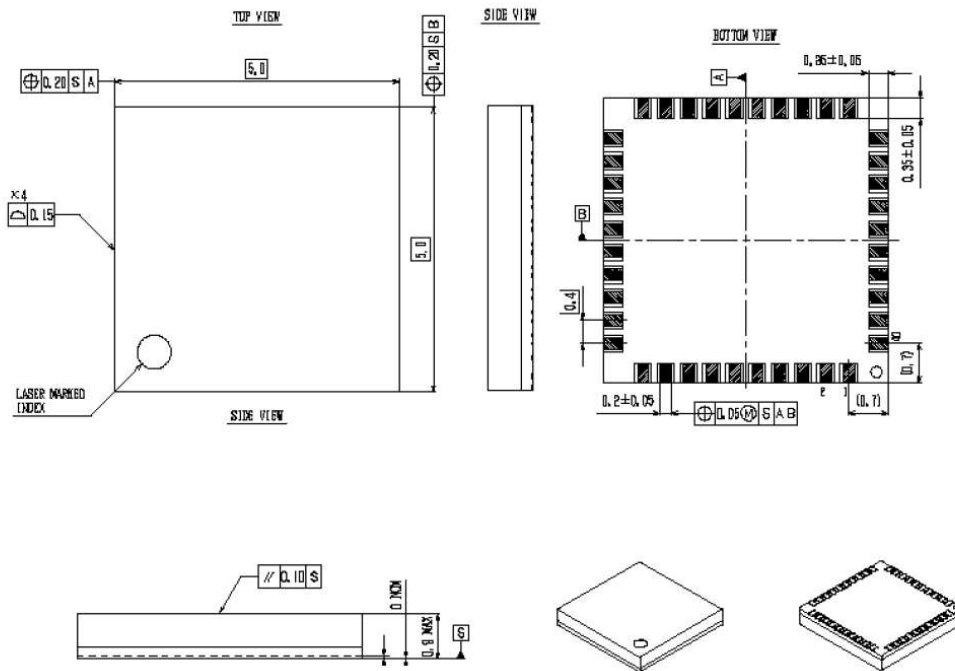
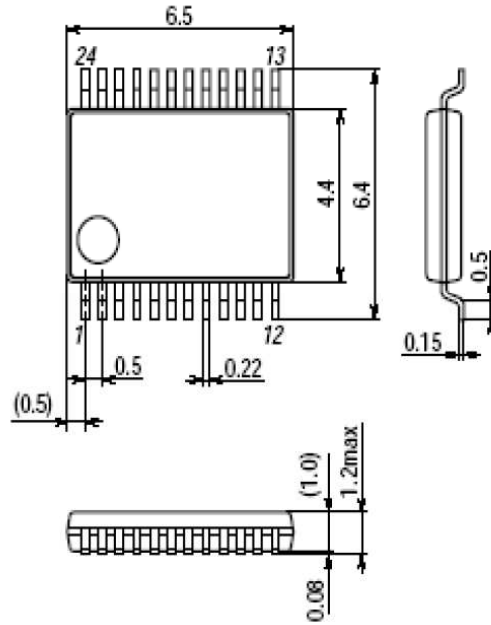

VQLP40 (5, 0x5, Q) X01

Specifications

Maximum Ratings at Ta =25°C

PARAMETER	SYMBOL	CONDITIONS	RATINGS	UNIT
Maximum Supply Voltage	VCC max	Analog Supply Voltage	6.0	V
	VDD max	Digital Supply Voltage	5.0	V
Digital Input Voltage	Vin1 max	Clock,Data,NR_W	Vdd+0.3	mA
	Vin2 max	External_clk_in	Vdd+0.3	V
Allowable Power Dissipation	Pd max	Ta≤70°C *note 40*0.8mm garaeposhi board	450	mW
Storage Temperature	Tstg		-40 ~ +125	°C
Operating Temperature	Topr		-20 ~ +70	°C

Operating Conditions at Ta = 25°C V_{CC} = V_{DD}

PARAMETER	SYMBOL	CONDITIONS	RATINGS	UNIT
Recommended Supply Voltage	VCC	Analog Block	3.0	V
	VDD	Digital Block	3.0	V
Operating Supply Voltage Range	VCC op		2.7 ~ 5.0	V
	VDD op		2.5 ~ 4.0	V
	VIO op	Interface Supply Voltage	1.8 ~ 4.0	V

Note:Power supply voltage VIO equal VDD,or Vio < Vdd (Vio≤Vdd)

Interface Conditions at Ta = from -20°C to +70 °C,V_{SS}=0V

PARAMETER	SYMBOL	CONDITIONS	Min	Typ	Max	Unit
Supply Voltage	V _{DD}		2.5	--	4.0	V
Digital part input	VIH	High level input voltage range	0.7VDD	--	VDD	V
	VIL	Low level input voltage range	0	--	0.6	V
Digital part Output	I OL	Low level output current	2.0	--	--	mA
	VOL	Low level output voltage IOL=2mA	--	--	0.6	V
Clock input Frequency	f _{clk}	3wire_bus (29pin)Clock Frequency	--	--	0.7	MHz
External clock Frequency	f _{clk_ext}	CLK_IN (31Pin)Frequency	32K	--	14M	Hz

Note: CLK_IN (31pin)can input sign wave.*Extertnl clock deviation is need 250ppm.

Operating Characteristics at Ta = 25°C, Vcc=3.0V , Vdd=3.0V , Vol=14, Soft Mute / Stereo=off

Vol=14 –Block2 register09h Volume_Bit 3-0 = 0010B

PARAMETER	SYMBOL	CONDITIONS	MIN	TYP	MAX	UNIT
Operational Supply Current	ICCA	Analog Block at 60dBu input The 23pin is measured *except LV24002 HP AMP current LV24000 LV24002	15	19	24	mA
	ICCD	Digital Block at 60dBu input The 27,40 pin are measured.	0.2	0.4	0.8	
Standby supply Current	ICCA	Analog standby mode The 23 pin is measured.	--	3	30	uA
	ICCD	Digital standby mode The 27,40 pins are measured.	--	3	30	
FM Coverd frq	F_range	See Appendix	76	--	108	MHz

PARAMETER	SYMBOL	CONDITIONS	MIN	TYP	MAX	UNIT
[FM Receiving characteristics ;MONO]:fc=80MHz,fm=1kHz,22.5kHzdev. soft_stereo,soft_mute,Buss,Treble are all OFF.						
Input limiting voltage	-3dB LS	Vin=60dB μ standard for a -3dB input	--	13	19	dB μ V EMF
Practical sensitivity	QS1	for 30dB signal to noise ratio input Deemphasis is 75 μ sec SG open	--	10	17	dB μ V EMF
Practical sensitivity	QS2	for 26dB signal to noise ratio input Deemphasis is 75 μ sec SG close	--	1.25	--	μ V
Demodulator Output level	Vo	Vin=60dBu, 11pin output level	60	100	140	mV
Channel balance	CB	Vin=60dBu, ratio of 11pin to 12pin output level	-2	0	2	dB
Signal to noise ratio	S/N	Vin=60dBu, 11pin output level	48	58	--	dB
Total harmonic distortion 1(MONO)	THD1	Vin=60dBu, 22.5KHzdev,11pin output	--	0.4	1.5	%
Total harmonic distortion 2(MONO)	THD2	Vin=60dBu, 75KHzdev,11pin output	--	1.3	3.0	%
Field strength level	FS	Input lever for FS1 to FS2	8	18	27	dBu
Muting attenuation	Mute-Att	Vin=60dBu, 11pin output level	60	70	--	dB
[FM Receiving characteristics ;STEREO]:fc=80MHz,fm=1kHz,Vin=60dB μ V,L+R=30%(22.5KHzdev),Pilot=10%(7.5KHzdev)						
Separation	SEP	L-mod,11pin→12pin output level	20	35	--	dB
Total harmonic distortion (STEREO)	THD-ST	Main-mod(L+R), 11pin/12pin output,IHF_BPF	--	0.6	1.8	%

[Head phone power characteristics ;LV24002]:Ta = 25°C VCC=3.0V,VDD=3.0V, fc=1KHz, RL=16Ω, Vol= 20(Max) Line input					
HP AMP Operation Supply Current	ICC_HPA1	Line input mode. no input	--	3	6 mA
HP AMP Standby supply Current	ICC_HPA2	Head_phone power off mode the 10 pin is measured.	--	3	40 μA
HPA power	Po_HPA	THD = 10% VR= MAX	3	--	-- mW
Total harmonic distortion	THD-HPA	Po=1mW	--	3	5 %
Output noise voltage	Vno	Rg=10KΩ, BPF=200Hz~15KHz,VR=14	--	0.03	0.3 mV

* VR=Max : Block2 register 09h Volume_Bit3-0 = 0000B setting and Block2 register 07h Volume sgift,bit6= 1 setting

LV24000 Pin layout

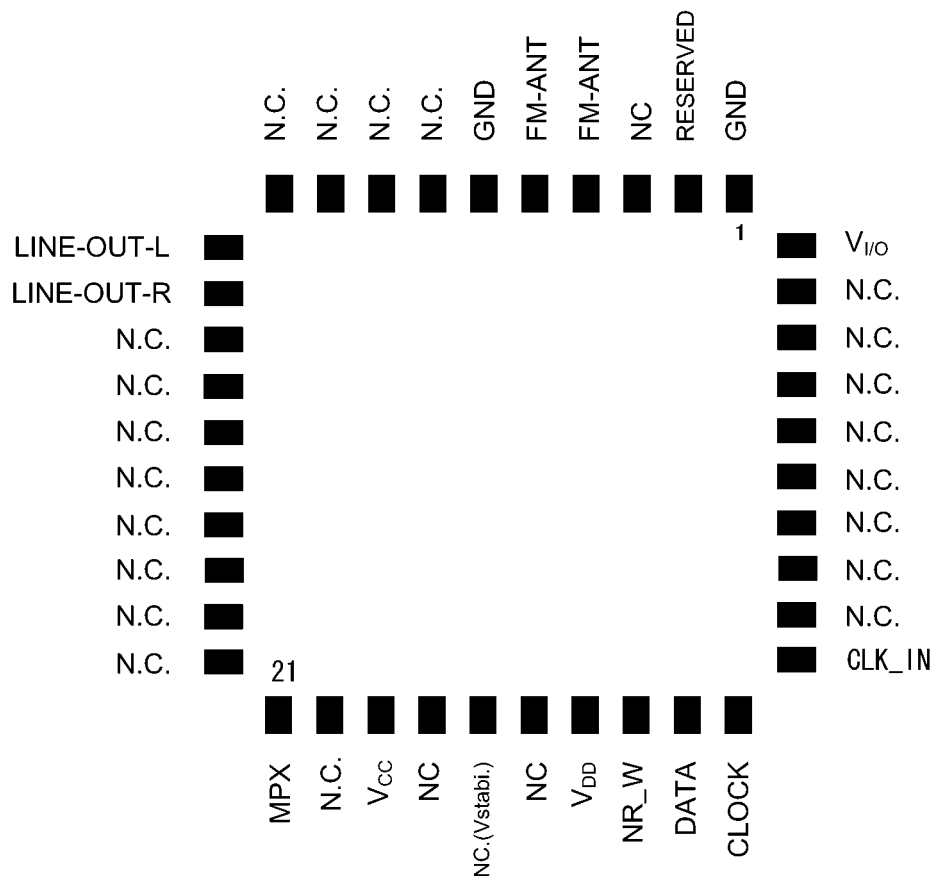
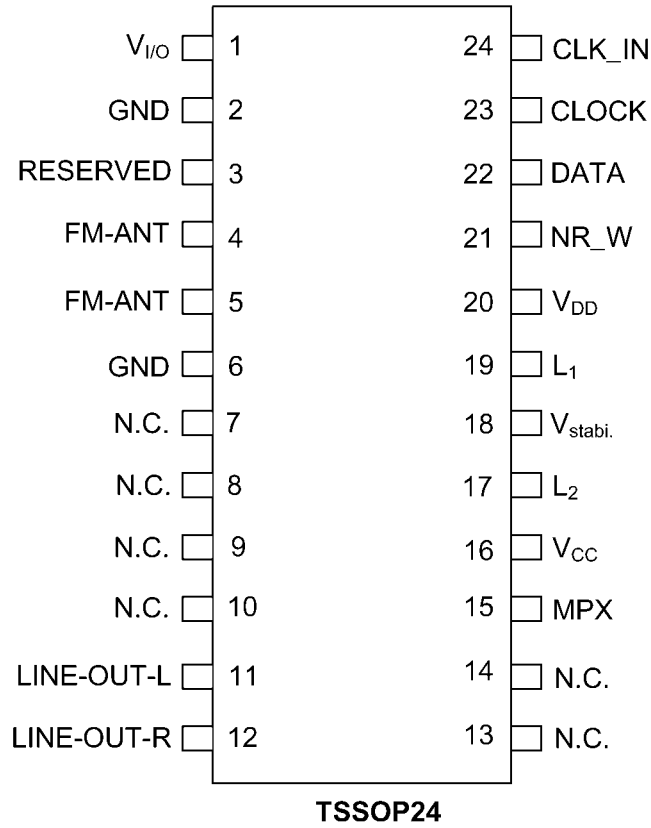

VQLP40 package Pin Description

Pin	LV24000PL	LV24002PL	Description	Remark	DC_bias
1	GND	GND	GND		
2	RESERVED	RESERVED		Do not connect	
3	NC	NC			
4	FM-ANT1	FM-ANT1	Antenna input		
5	FM-ANT2	FM-ANT2	Antenna GND	Connect to GND	
6	GND	GND	Vss		
7	NC	HEADPH_R	Headphone Rch output		1.2V
8	NC	HEADPH_C	Headphone common	Not DC GND	1.2V
9	NC	HEADPH_L	Headphone Lch output		1.2V
10	NC	VCC2	Headphone supply voltage		
11	LINE-OUT-L	LINE-OUT-L	Radio Lch Line-output		1.2V
12	LINE-OUT-R	LINE-OUT-R	Radio Rch Line-output		1.2V
13	NC	NC			
14	NC	NC			
15	NC	NC			
16	NC	NC			
17	NC	NC			
18	NC	NC			
19	NC	LINE-IN-R	Rch Line-input		1.4V
20	NC	LINE-IN-L	Lch Line-input		1.4V
21	MPX	MPX	MPX-signal output		Vcc-0.3V
22	NC	NC			
23	VCC	VCC	Analog supply voltage		
24	NC (L2)	NC (L2)	Internal coil2	Do not connect	2.7V
25	Vstabi.	Vstabi.	Stabilizer voltage		2.7V
26	NC (L1)	NC (L1)	Internal coil1	Do not connect	2.7V
27	VDD	VDD	Digital supply voltage		
28	NR_W	NR_W	Digital interface Read/Write		
29	DATA	DATA	Digital interface DATA		
30	CLOCK	CLOCK	Digital interface Clock		
31	CLK_IN	CLK_IN	Reference clock-source input for measurement	Connect to GND if not used	
32	NC	NC			
33	NC	NC			
34	NC	NC			
35	NC	NC			
36	NC	NC			
37	NC	NC			
38	NC	NC			
39	NC	NC			
40	VI/O	VI/O	Digital interface supply voltage		

LV2400LP_Block Diagram

VQLP40 package

Top_View

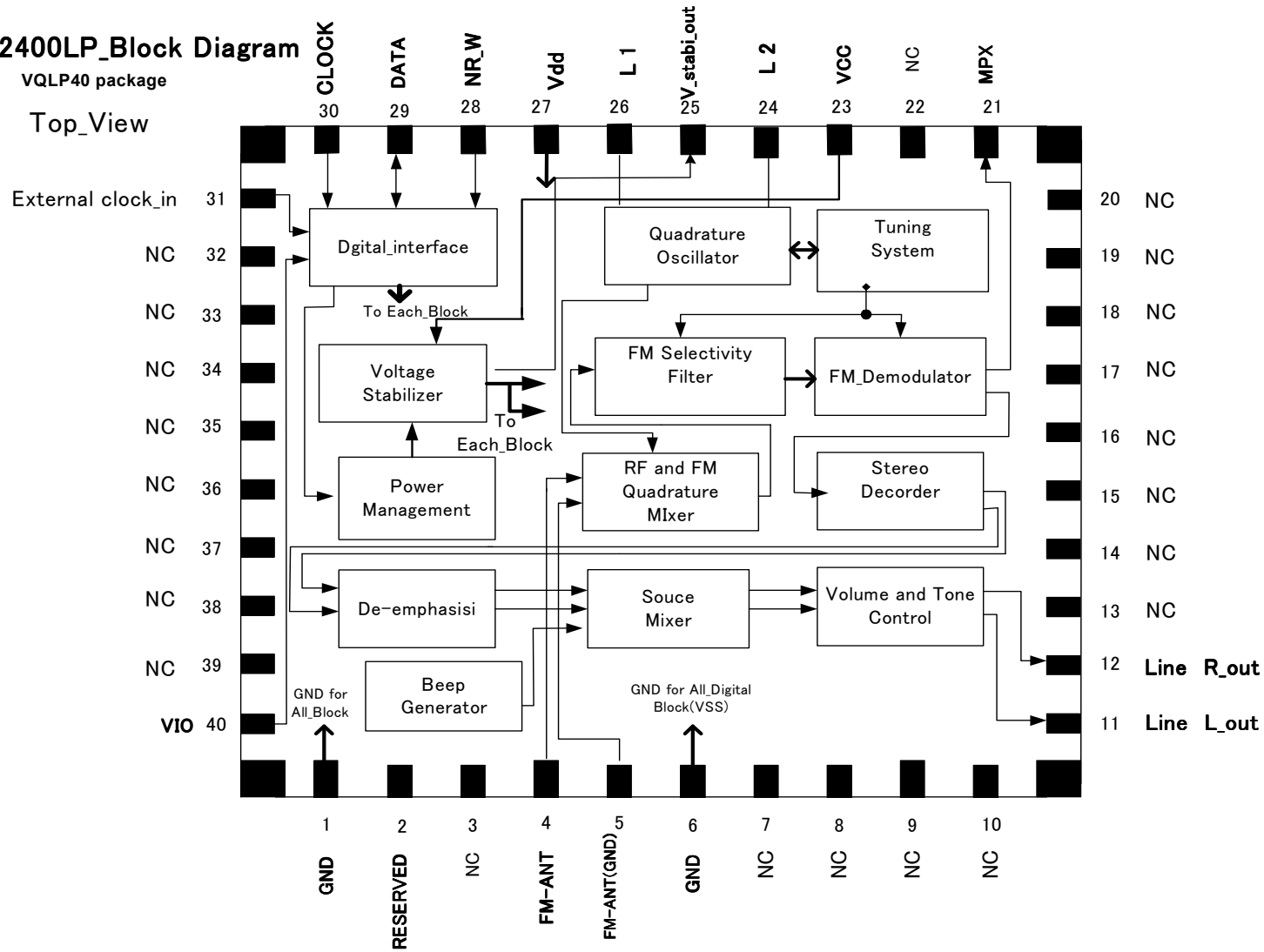

LV24002LP_Block Diagram

VQLP40 package
Top_View

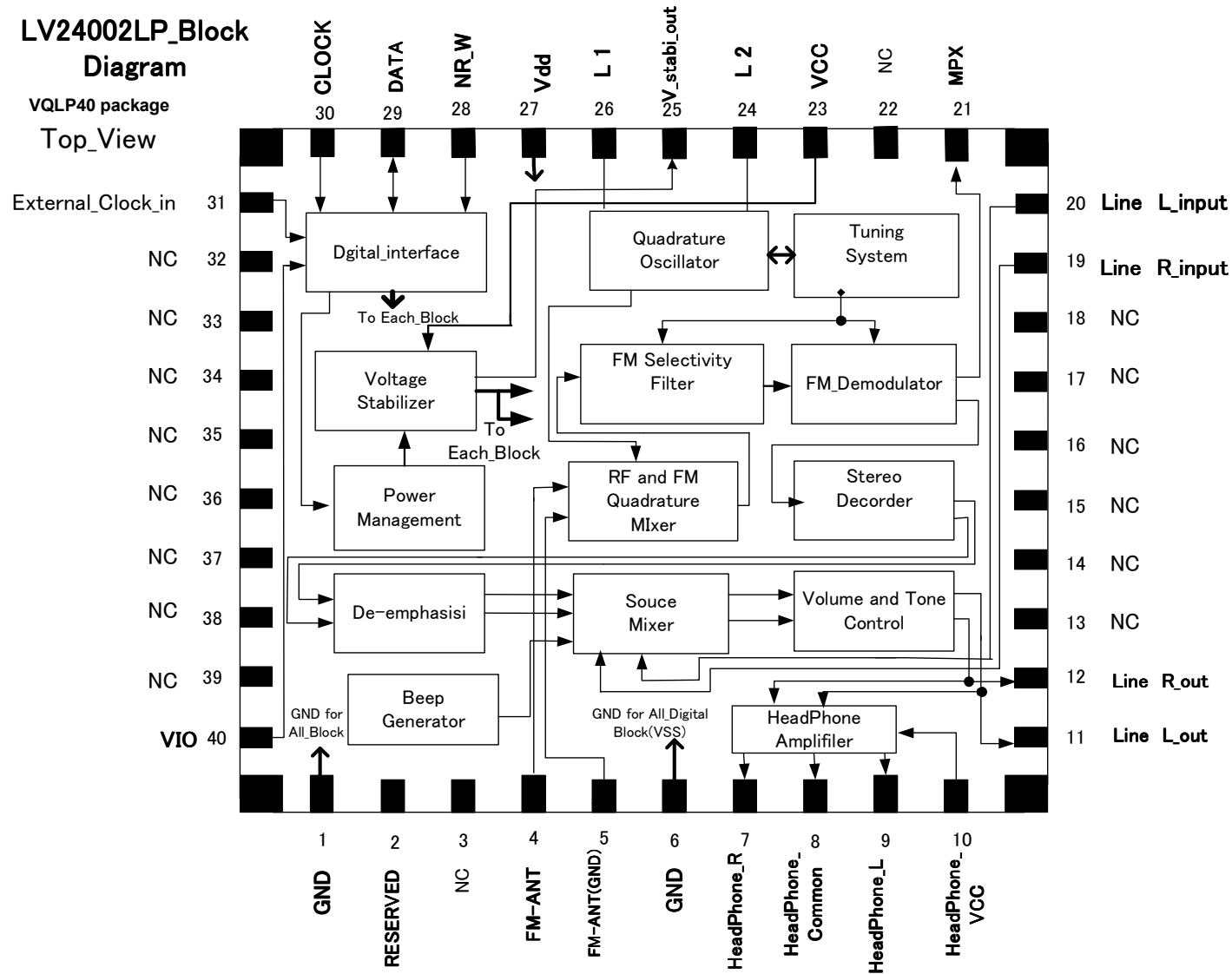

LV24000 Measurement_circuit

VQLP40 package

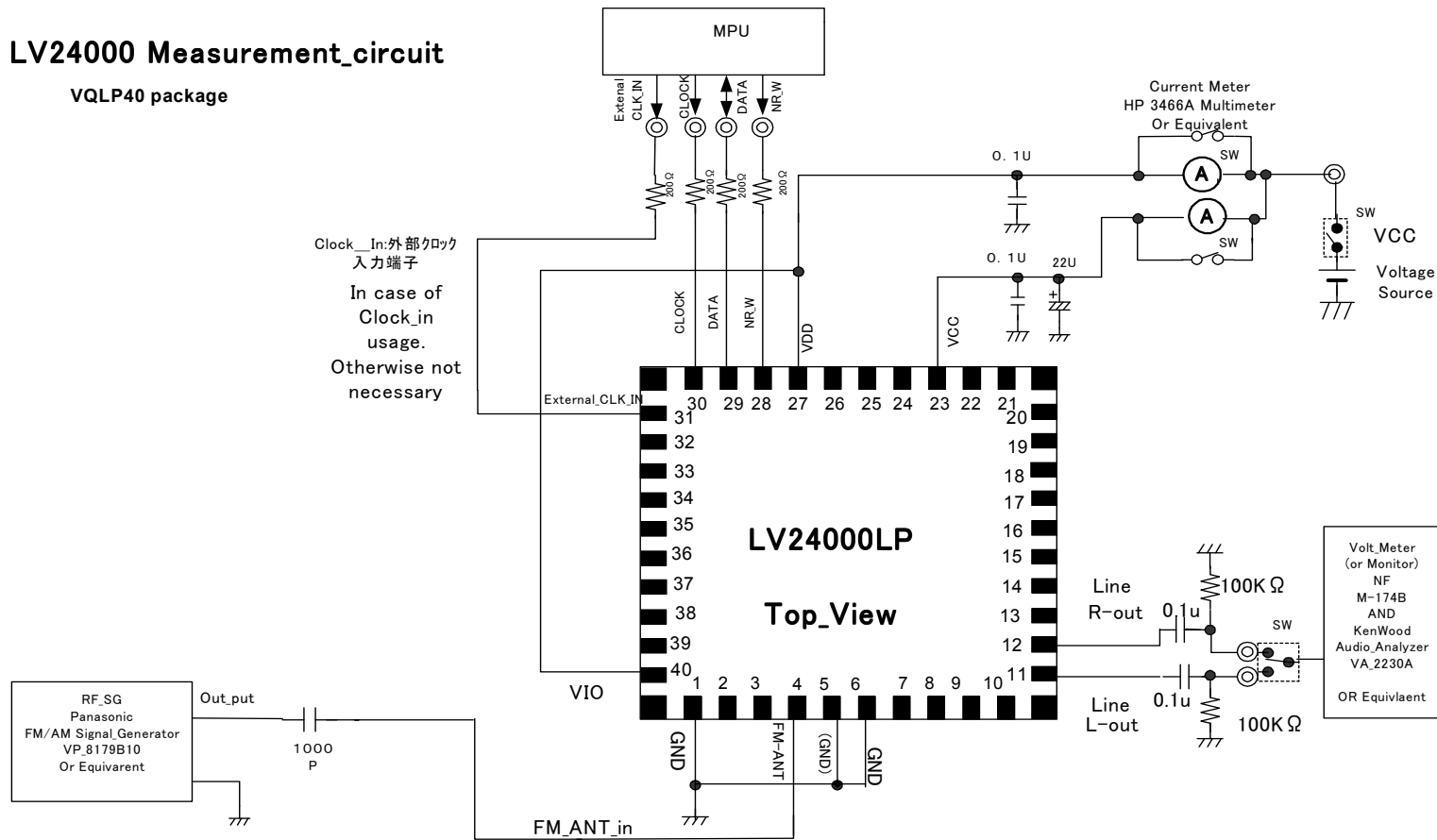

LV24002 Measurement_circuit

Measurement_circuit When Separating Antenna-input and Head_phon-out

VQLP40 package

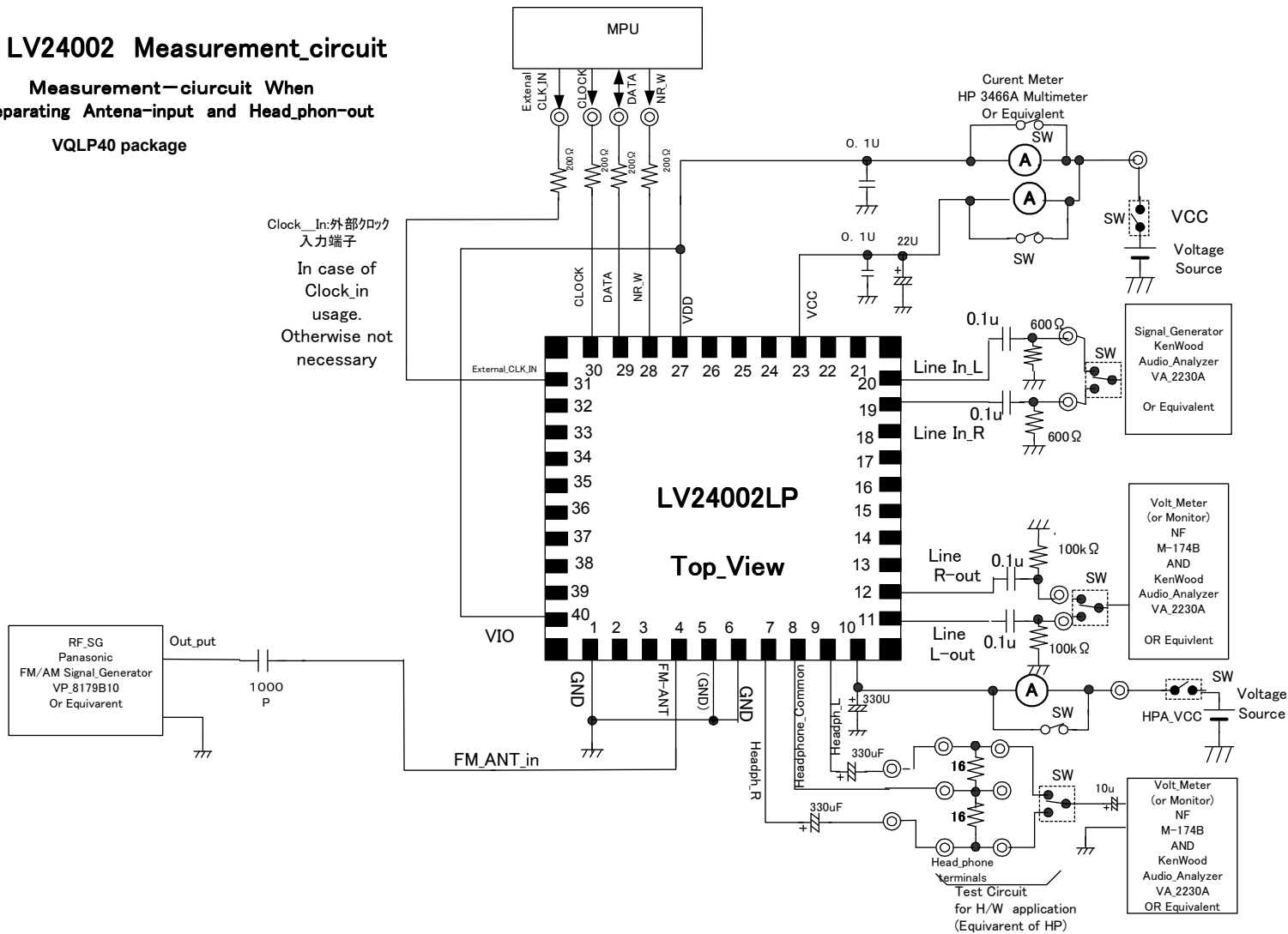

LV2400LP application_circuit

VQLP40 package

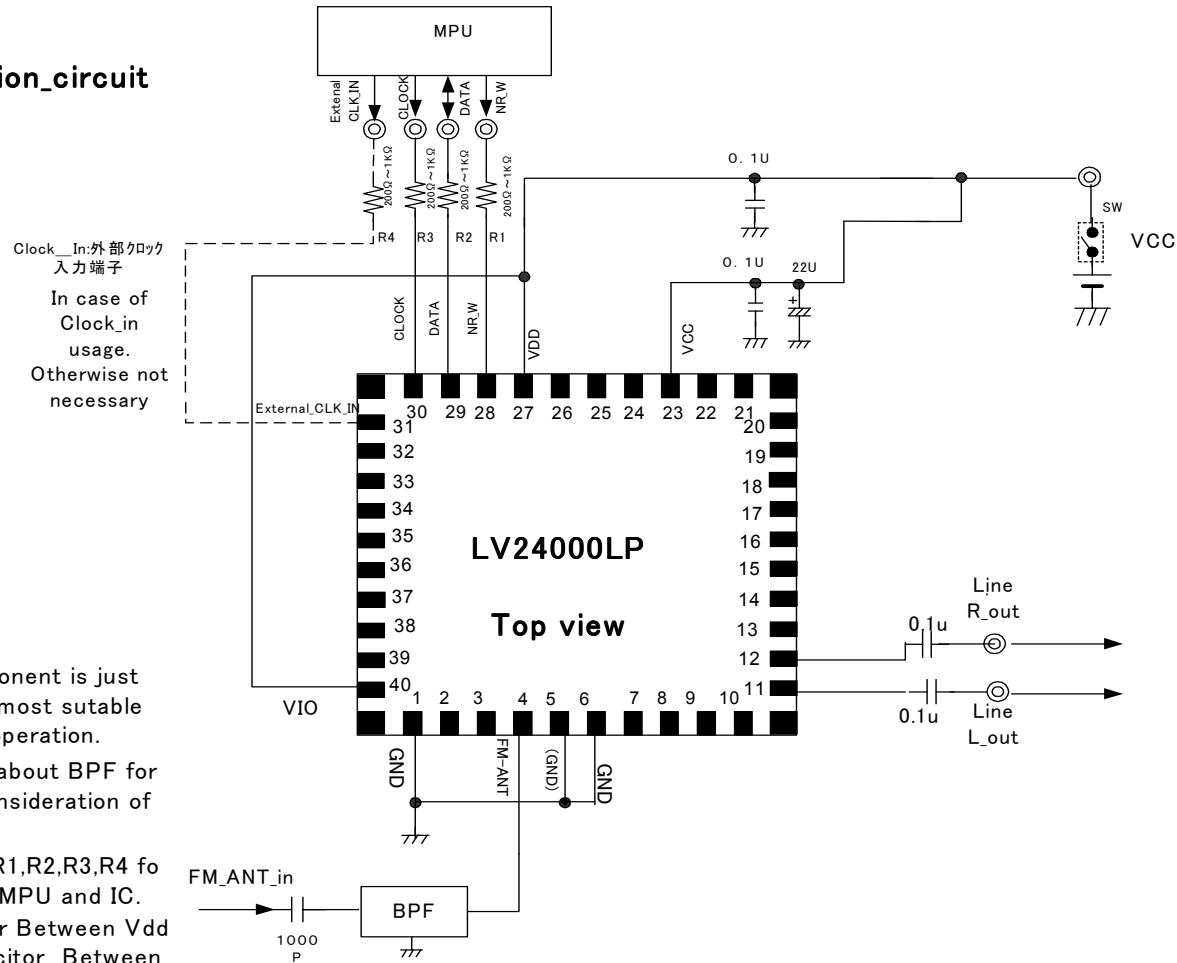

LV24002LP application_circuit

VQLP40 package

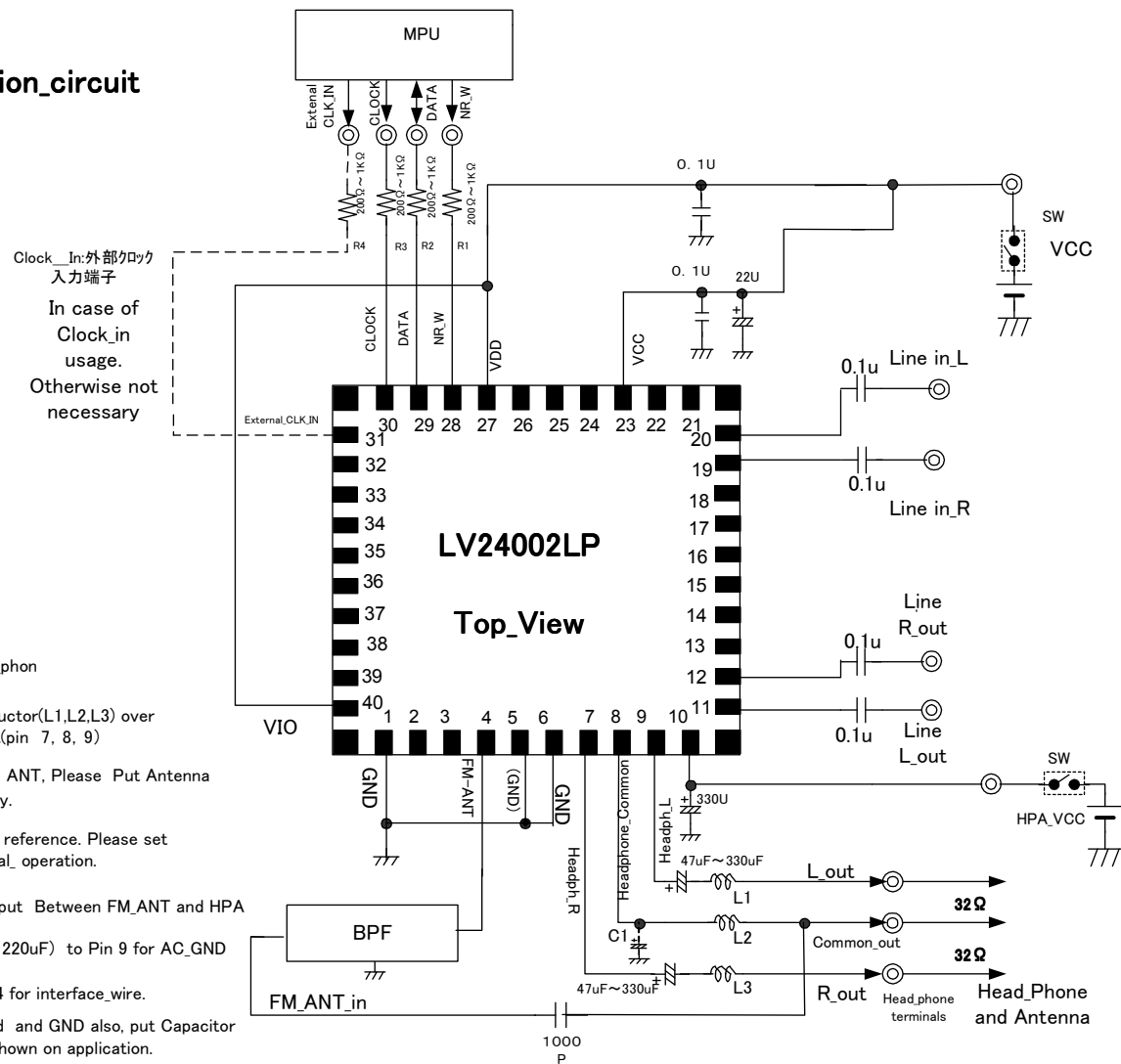

Clock_in:外部クロック
入力端子
In case of
Clock_in
usage.
Otherwise not
necessary

- Note1: Recommend to use 32ohm Head_phon
- Note2: Recommend to use Value of Inductor(L1,L2,L3) over 820nH for Head_phone_out put(pin 7, 8, 9)
- Note3: In case of not use Head_phone for ANT, Please Put Antenna Circuit ceperatly.
- Note4: Vale of Extenal Component is just reference. Please set most sutable value under Aactual_ operation.
- Note5: In case of necessary BPF, Please put Between FM_ANT and HPA
- Note6: We recommend to put C1(100uF~220uF) to Pin 9 for AC_GND
- Note7: We recommend to put R1,R2,R3,R4 for interface_wire.
- Note8: Please put Capacitor Between Vdd and GND also, put Capacitor Between Vcc and GND as shown on application.