

# TDA9975

Complementing its broad data converter and DVI receiver offering for video interface, Philips Semiconductors portfolio is now presenting a state-of-the-art combination of HDMI receiver (High Definition Multimedia Interface) and analog-to-digital video interface technology. This device enables TV manufacturers to easily comply with the new HDMI standard required for new generation TVs. At the same time, TV makers remain compliant with all analog standards, from PAL/NTSC interlaced to 720p and 1080i HDTV.



## Features

### AVI Receiver

- 3 selectable RGB/YUV analog video inputs from 0.5 Vpp to 1 Vpp
- Triple AVI (AGC + Clamp + 10-bit ADC)
- 100 Mhz analog bandwidth
- PLL programmable via I<sup>2</sup>C bus interface
- Pixel Clock from 12 up to 81 Msp/s generated by internal PLL
- Sync separator / extractor to comply with all analog Video formats (Interlaced and Progressive)
- Accept SOG, Composite Sync, separate H and V input signals
- Low PLL jitter for high accuracy sampling and enhanced picture quality
- Flexible configuration with I<sup>2</sup>C (200 registers)
- Polarity and activity detection
- Parasite synchronization pulse detection and suppression

### HDMI Receiver

- 2 HDMI 1.0 selectable inputs (backward compatible with DVI 1.0)
- 110 Mpix/s digital throughput
- Digital audio output via S/PDIF-bus or four I<sup>2</sup>S-busses
- Embedded HDCP1.1 de-ciphering function with software encryption for secure loading of the keys

### Features common to AVI and HDMI

- Compatible to all video standard from TV: PAL / NTSC / HDTV up to VESA: XGA 75 Hz Activity detection on inputs Fully programmable colour space conversion function (YpbPr < - > RGB)
- Digital video output format RGB 4:4:4, YUV 4:4:4, YUV 4:2:2 ITU-656 or YUV 4:2:2 semi-planar standard, using up to three parallel 12-bit output busses
- Power management. Power consumption of 1.3 W
- 1.8V and 3.3V power supplies
- SQFP208 and LPGA256 package

Triple 10-bit analog-to-digital video interface with HDMI receiver for new generation TVs up to 81 Msp/s



## Description

The TDA9975 is optimized for new TV applications using YUV / RGB based processors, either in CCIR656 or CCIR601 (YpbPr semi-planar) formats. It combines an analog path with a triple 10-bit ADC up to 81 MSPS, and a digital path with two selectable single link HDMI receivers. Both signal paths are processed through a highly flexible digital block including a fully programmable RGB to YUV—and reverse—matrix, down-sampling filters and digital output formatters (including EAV / SAV information insertion in case of CCIR 656). This enables users to choose RGB or YUV 4:4:4, YUV 4:2:2 (CCIR601 or 656) outputs, whatever is the best for their system. In addition, there is no loss of resolution regardless of whether the inputs are RGB, YUV or HDMI.

The TDA9975 includes a highly configurable sync separator, avoiding the use of an external device. It is compatible with all standard analog video sources from VCR to HDTV thru DVD and Set Top Box. A copy protection scheme complying to the HDCP 1.1 (High-bandwidth Digital Content Protection) standard is added to the interface. HDCP keys are loaded via I<sup>2</sup>C after being securely encrypted by a dedicated software. The TDA9975 is packaged in a SQFP208 and LPGA256.

The TDA9974 includes the HDMI receiver and digital processing functions of the TDA9975.

The TDA9970 includes the HDMI receiver function of the TDA9975, combined with a 8-bit resolution analog path.

## Applications

- PDP TV
- LCD TV
- CRT TV
- Home theater projectors
- Rear Projection TV
- Home theater receivers

# PHILIPS

# TDA9975

Triple 10-bit analog-to-digital video interface with HDMI receiver  
for new generation TVs up to 81 Msp



TDA9975 block diagram

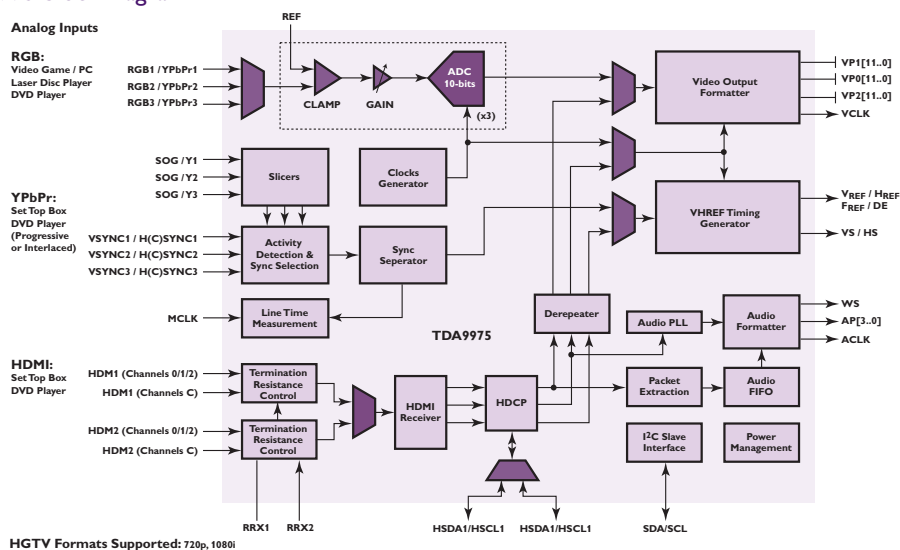

## Typical application of TDA9975

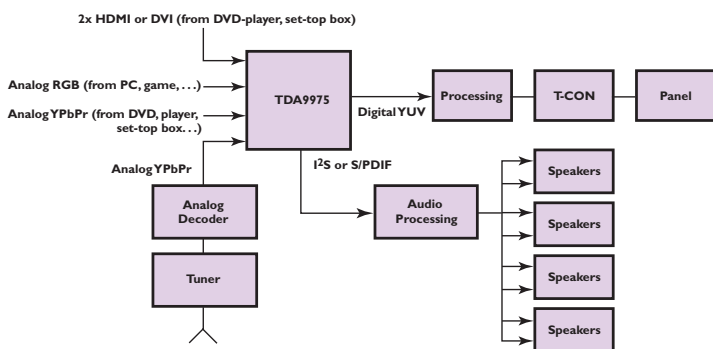

## HDMI receiver range quick description

	TDA9975	TDA9974	TDA9970
Analog path	10-bit	No	8-bit
Two HDMI links	Yes	Yes	Yes
Package	SQFP208 / LBGA256	SQFP208	SQFP208

- [1] DVI specification published by Digital Working Group (DDWG) promoters and may have related patents and/or patent applications.
- [2] HDCP is software designed by Intel/Silicon Image. All trademark rights belong to the respective producers.
- [3] HDMI is a registered trademark of the High Definition Multimedia Interface consortium. HDMI specifications are issued by the HDMI working group. Use of the ICs do not imply the granting of licenses.

## Philips Semiconductors

Philips Semiconductors is a worldwide company with over 100 sales offices in more than 50 countries. For a complete up-to-date list of our sales offices please e-mail [sales.addresses@www.semiconductors.philips.com](mailto:sales.addresses@www.semiconductors.philips.com). A complete list will be sent to you automatically. You can also visit our website <http://www.semiconductors.philips.com/sales>

© Koninklijke Philips Electronics N.V. 2003

All rights reserved. Reproduction in whole or in part is prohibited without the prior written consent of the copyright owner. The information presented in this document does not form part of any quotation or contract, is believed to be accurate and reliable and may be changed without notice. No liability will be accepted by the publisher for any consequence of its use. Publication thereof does not convey nor imply any license under patent- or other industrial or intellectual property rights.

